

YoU Ceiling - DV set



YoU Ceiling FIG 1 - FIG 3

FIG 1

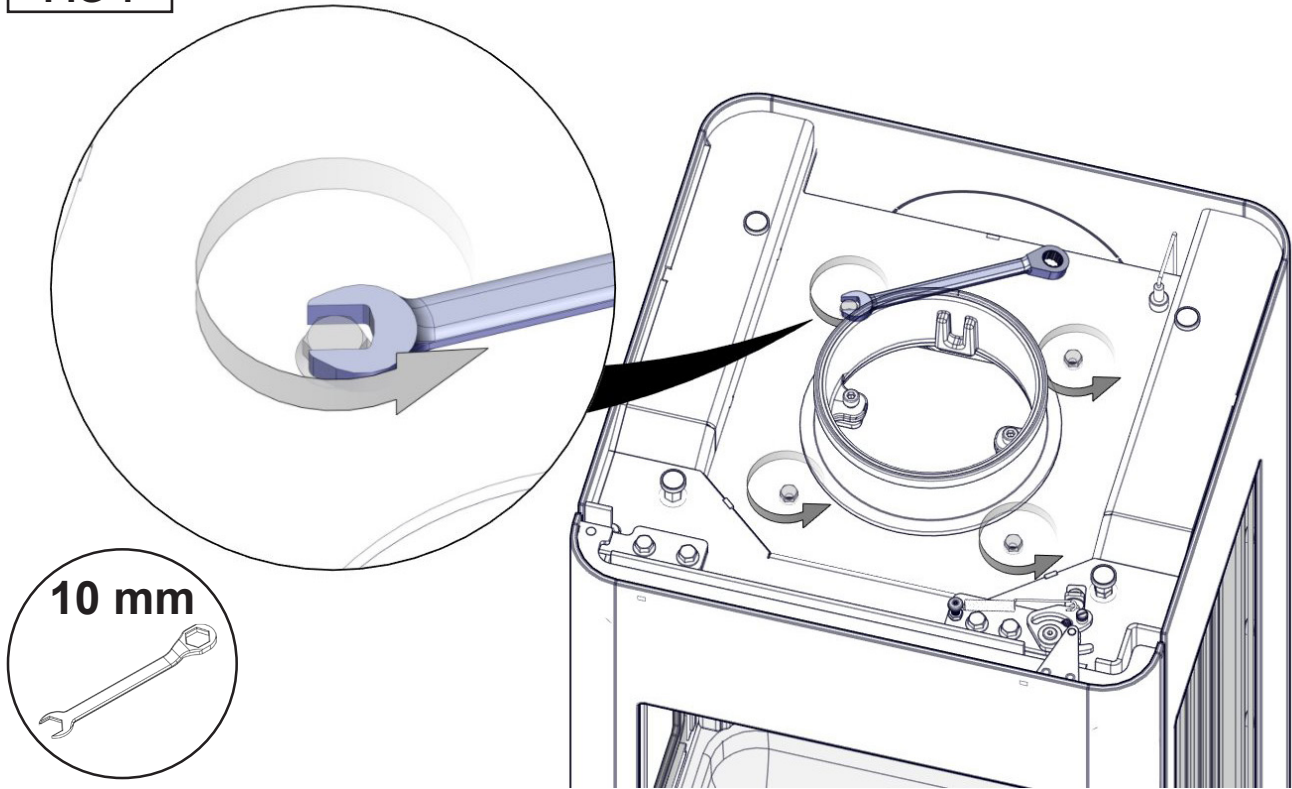

FIG 2

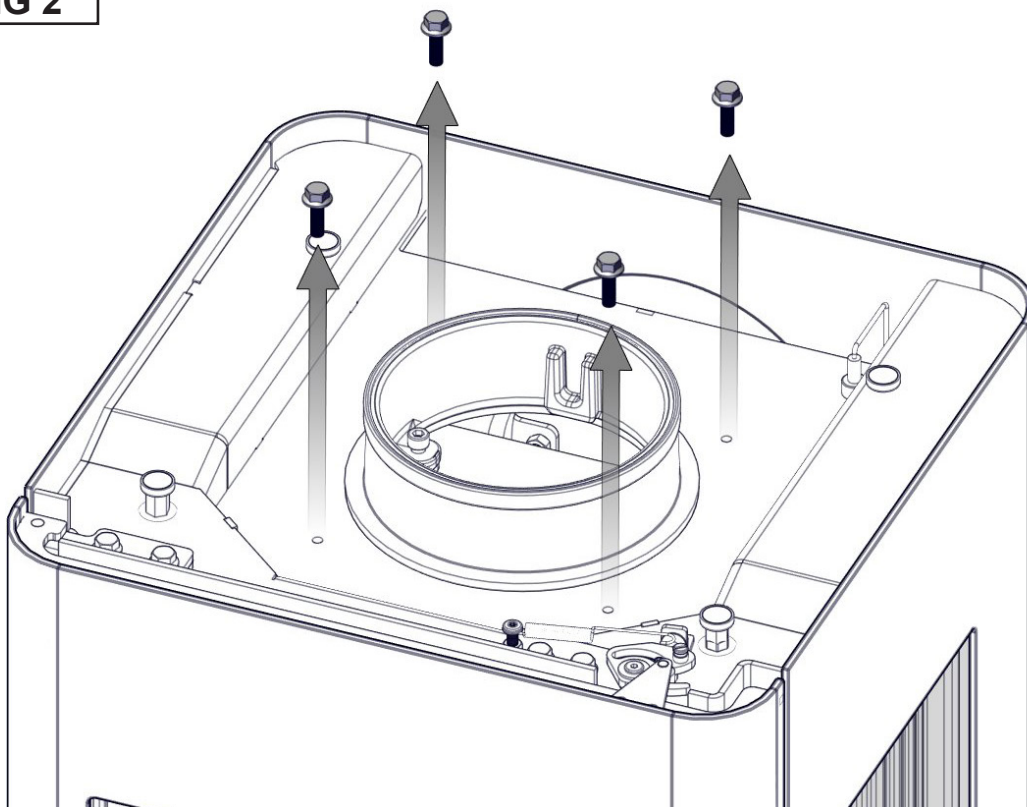

FIG 3

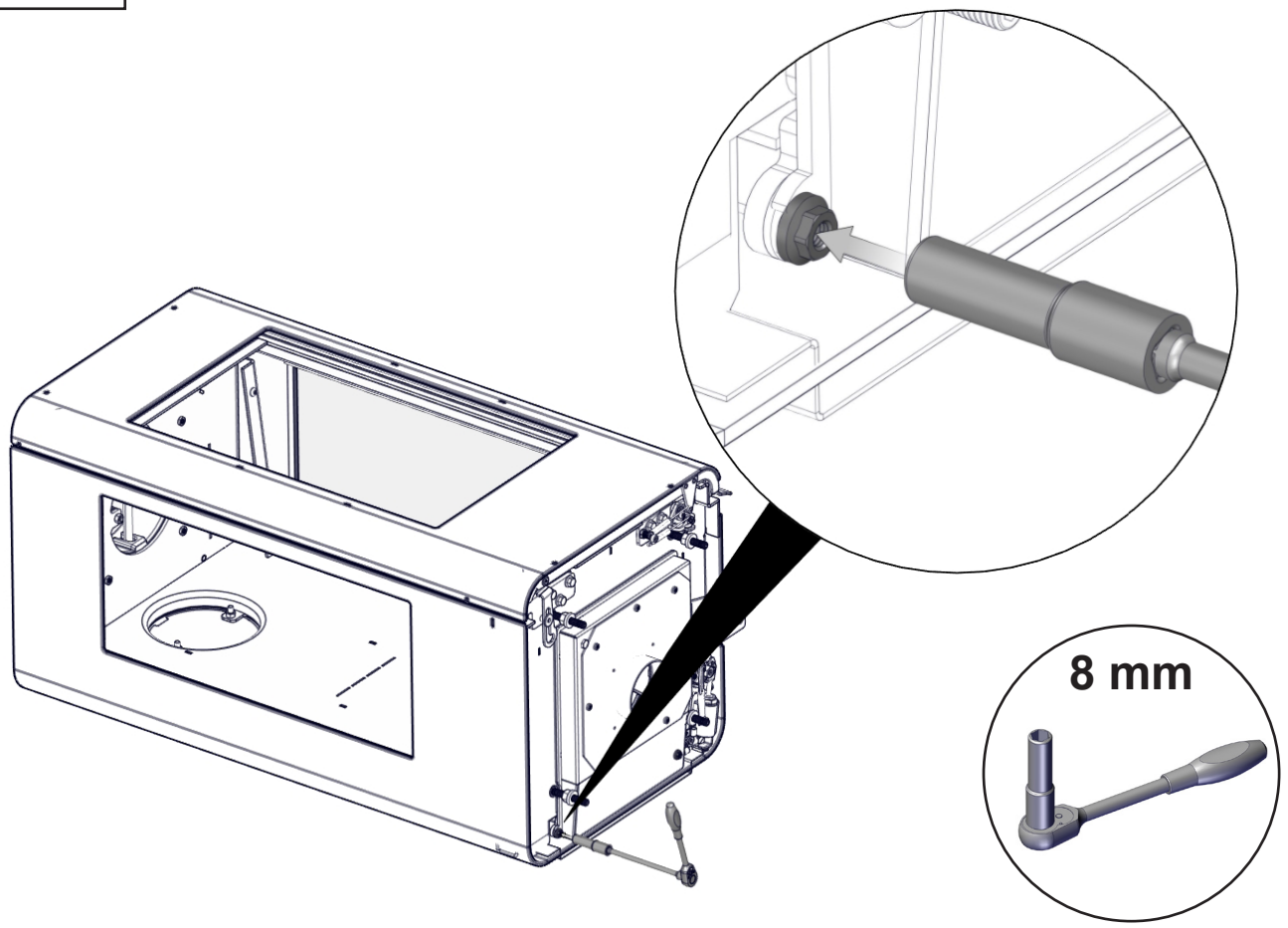

FIG 4

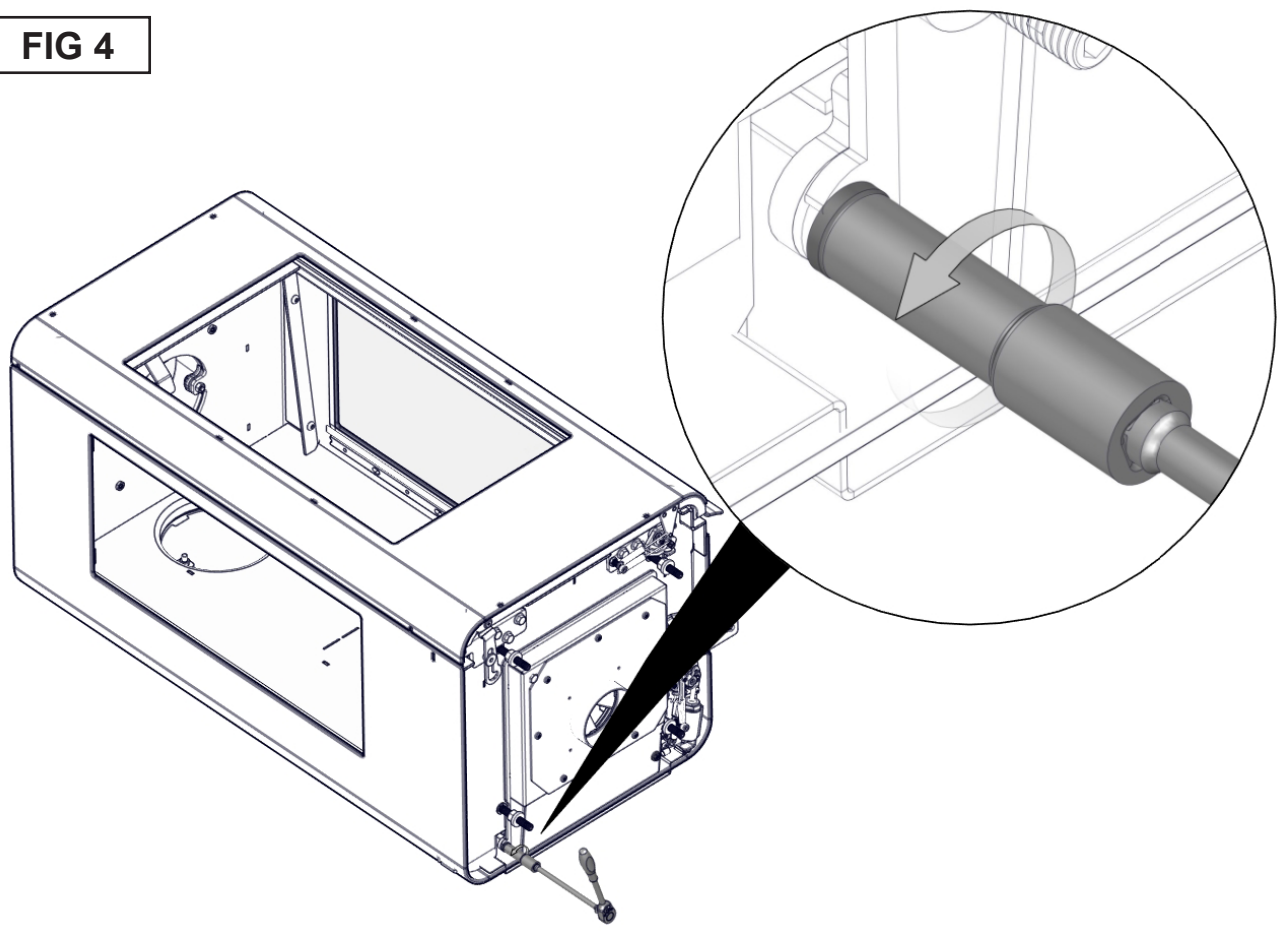

FIG 5

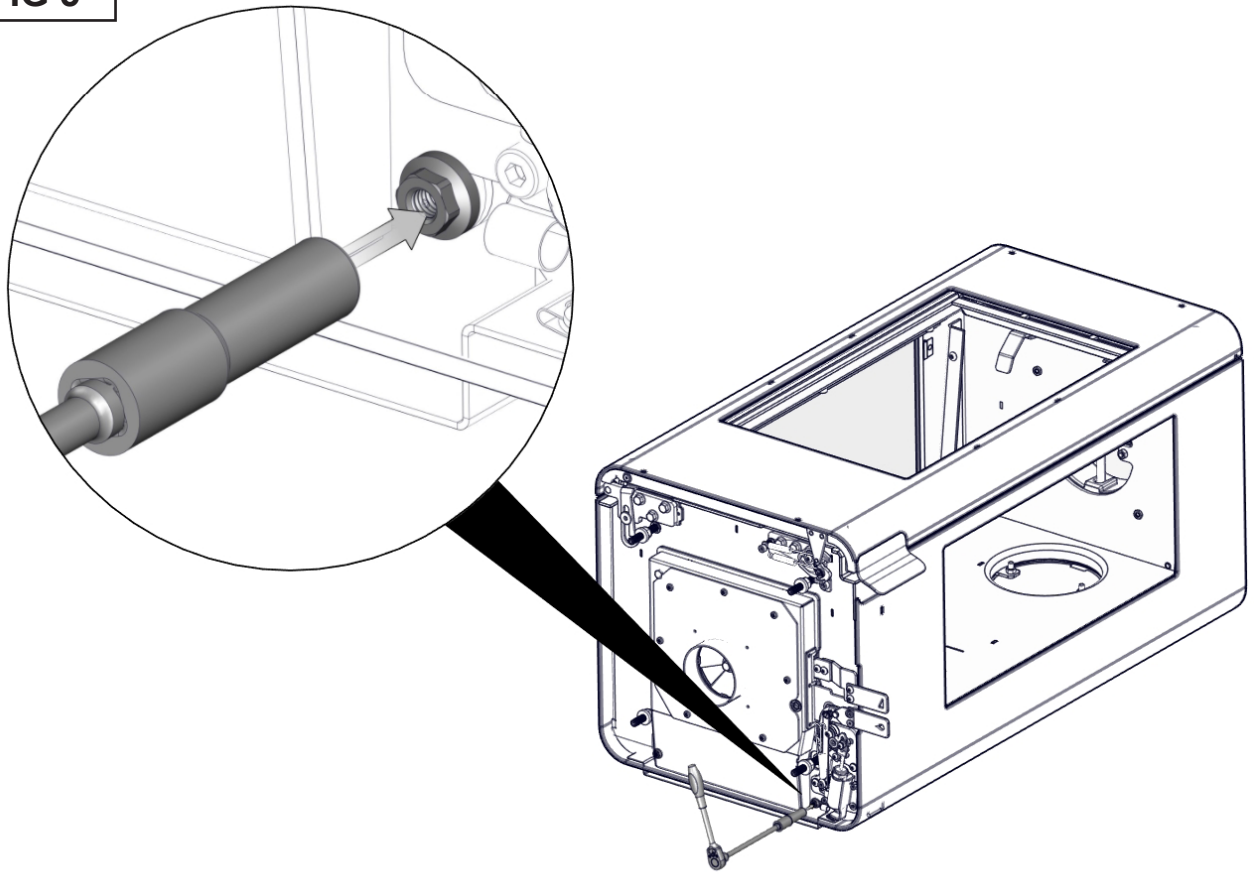

FIG 6

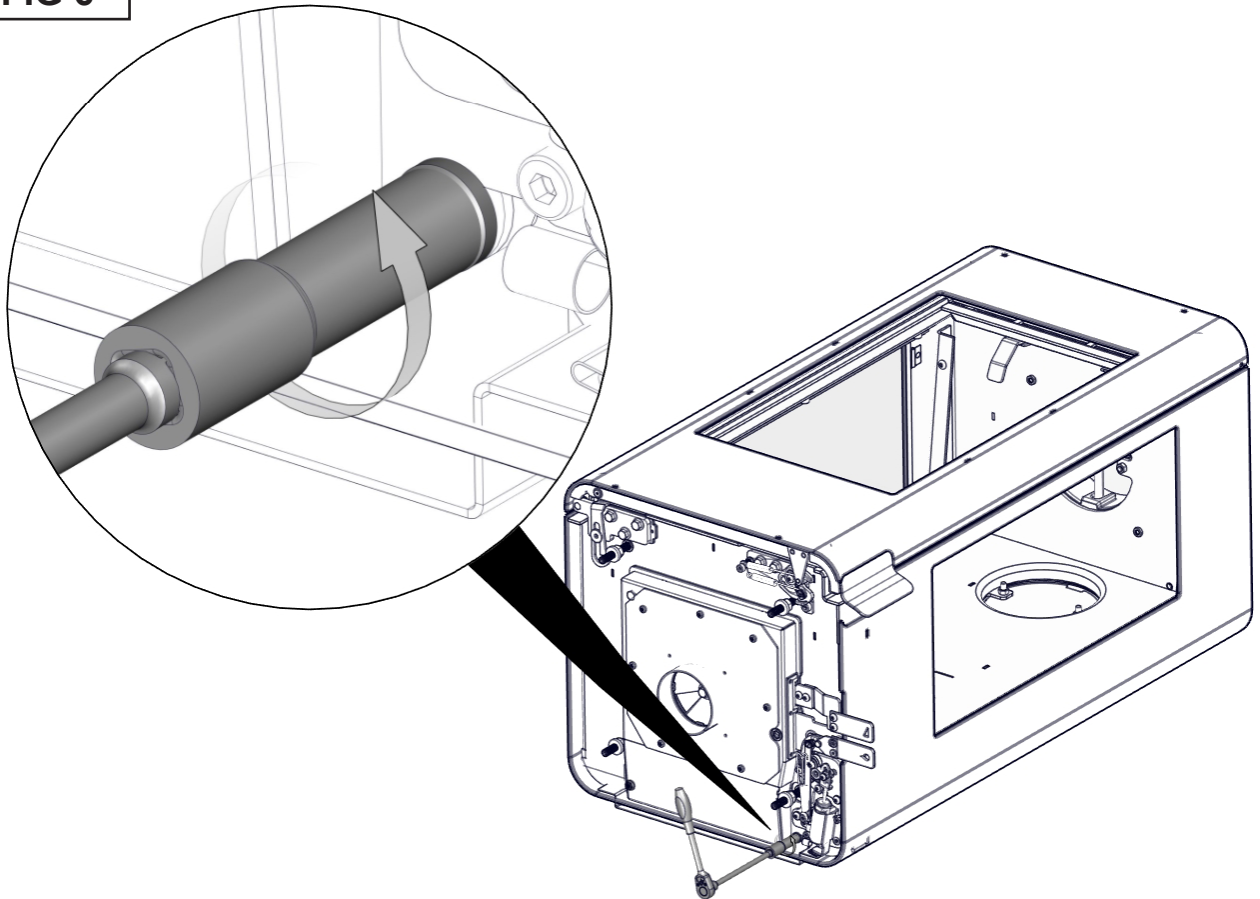

FIG 7

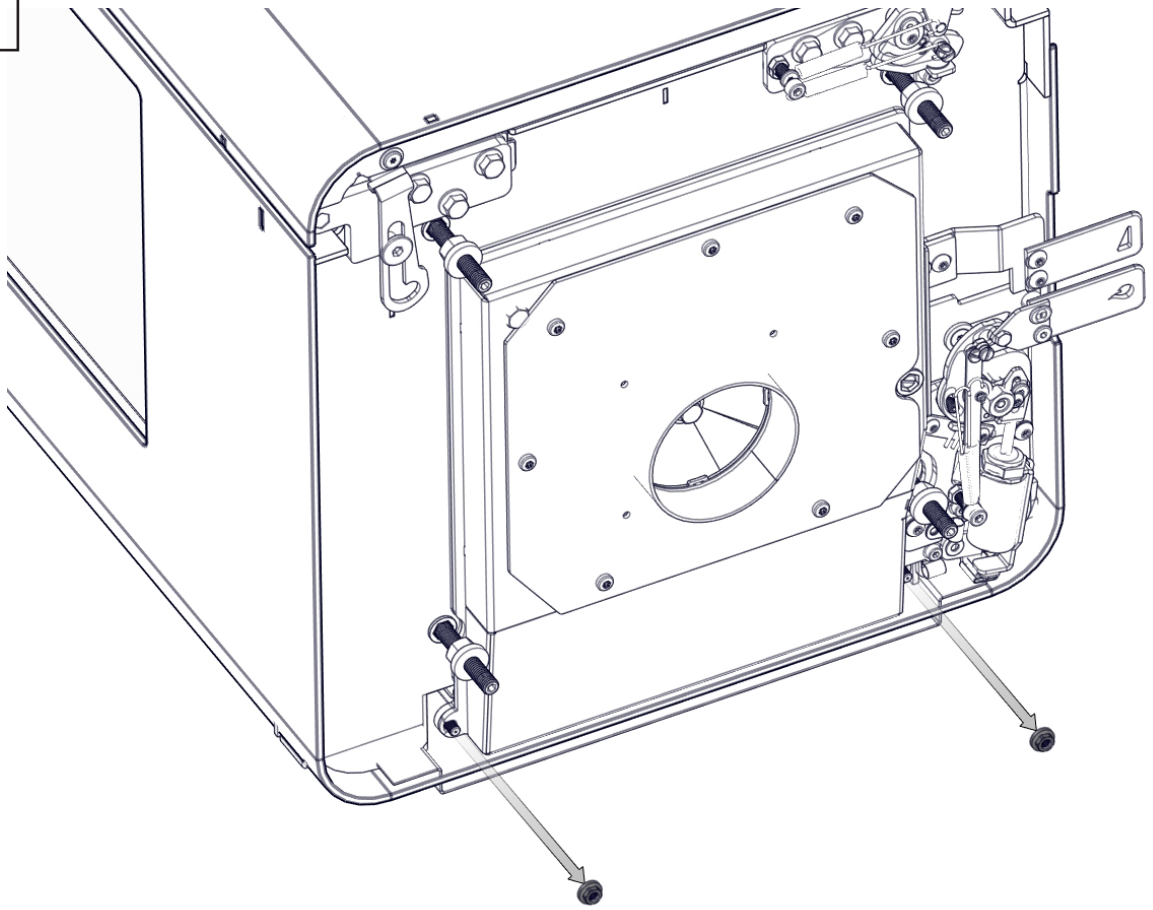

FIG 8

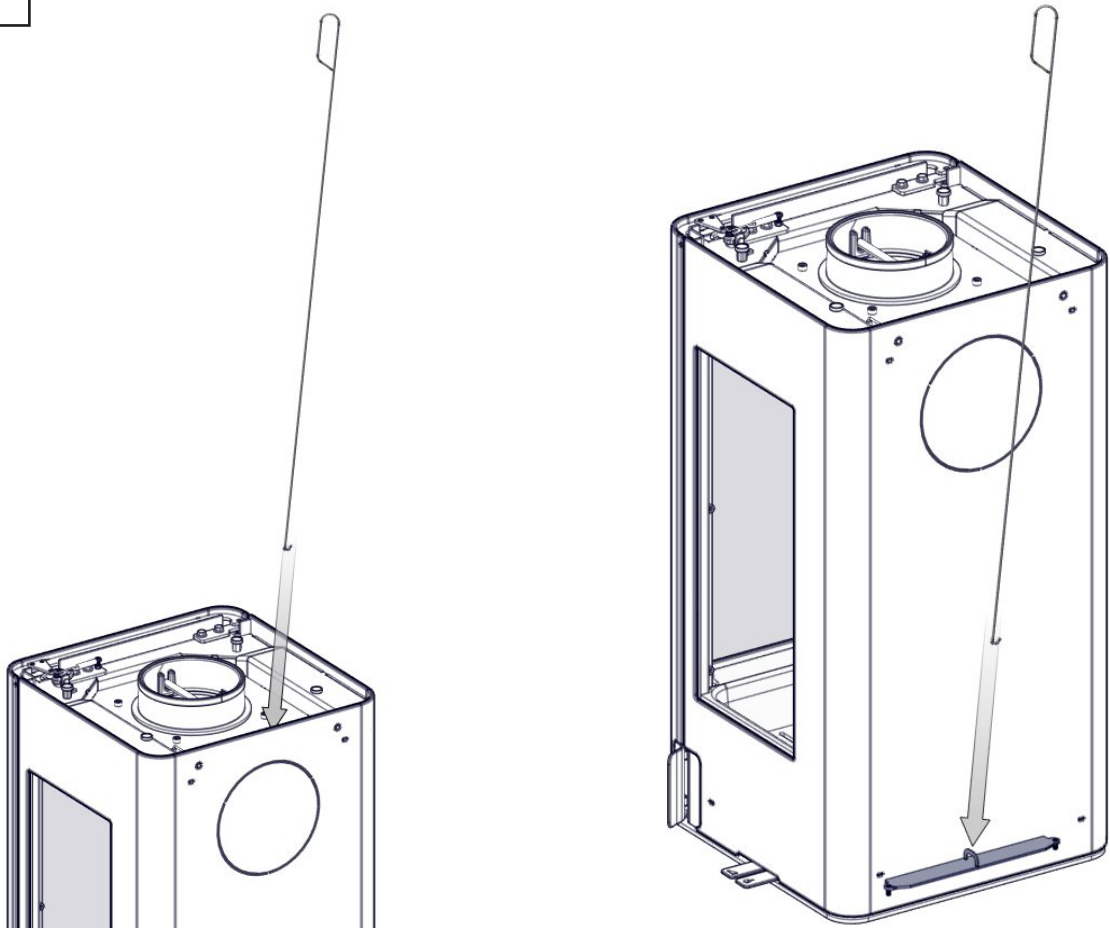

FIG 9

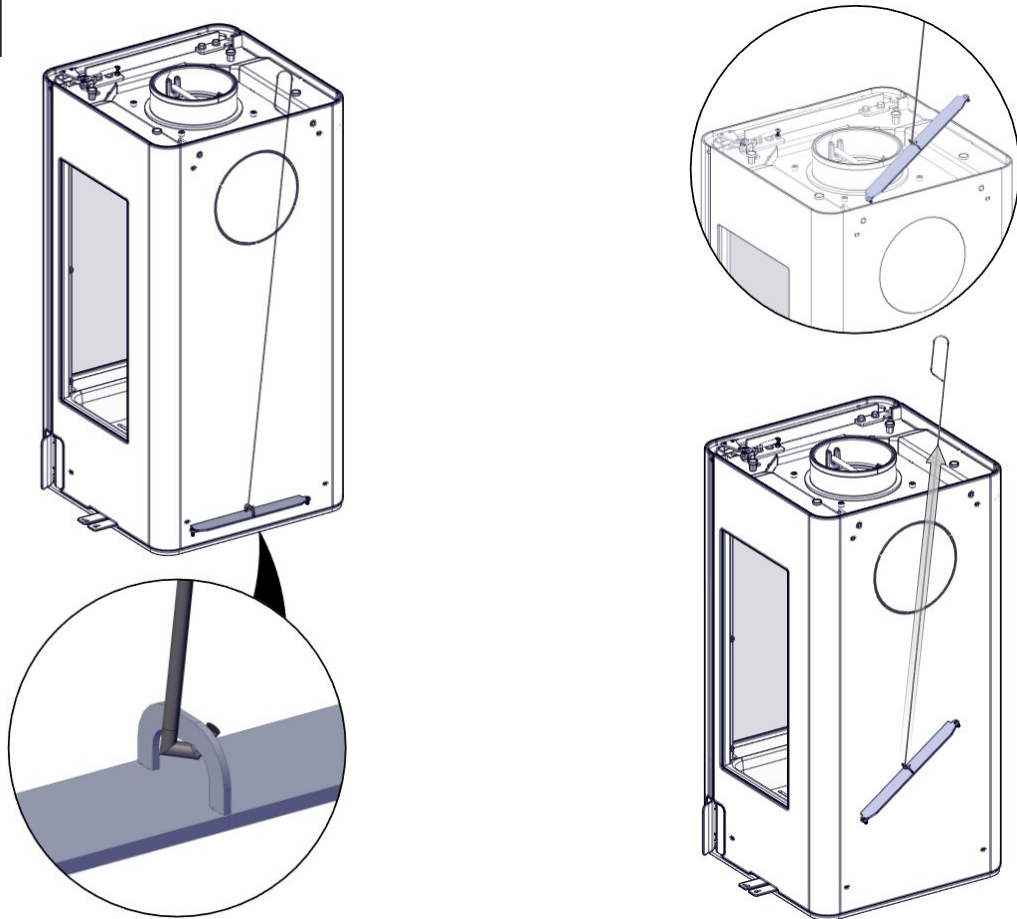

FIG 10

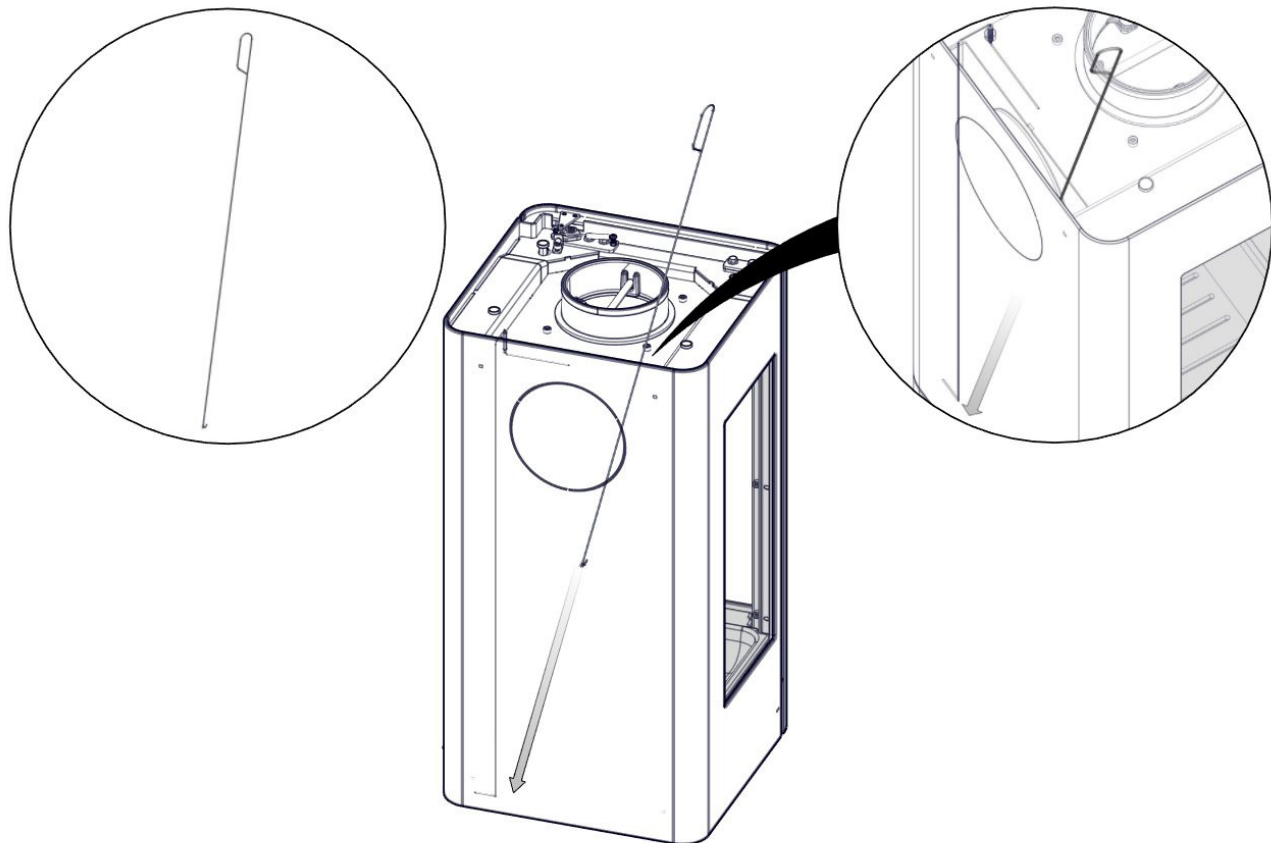

FIG 11

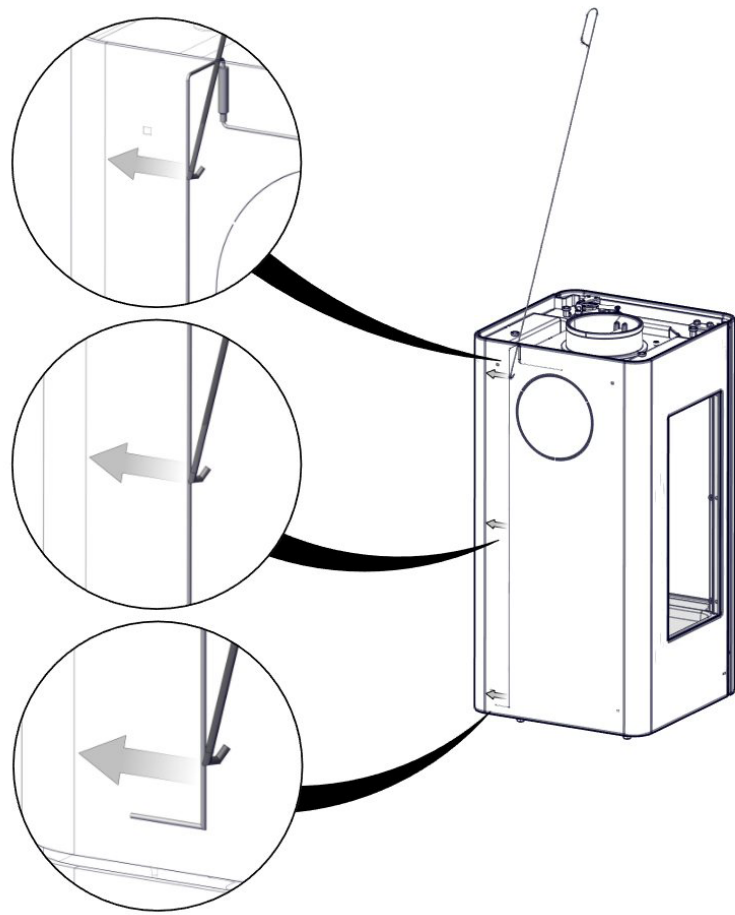

FIG 12

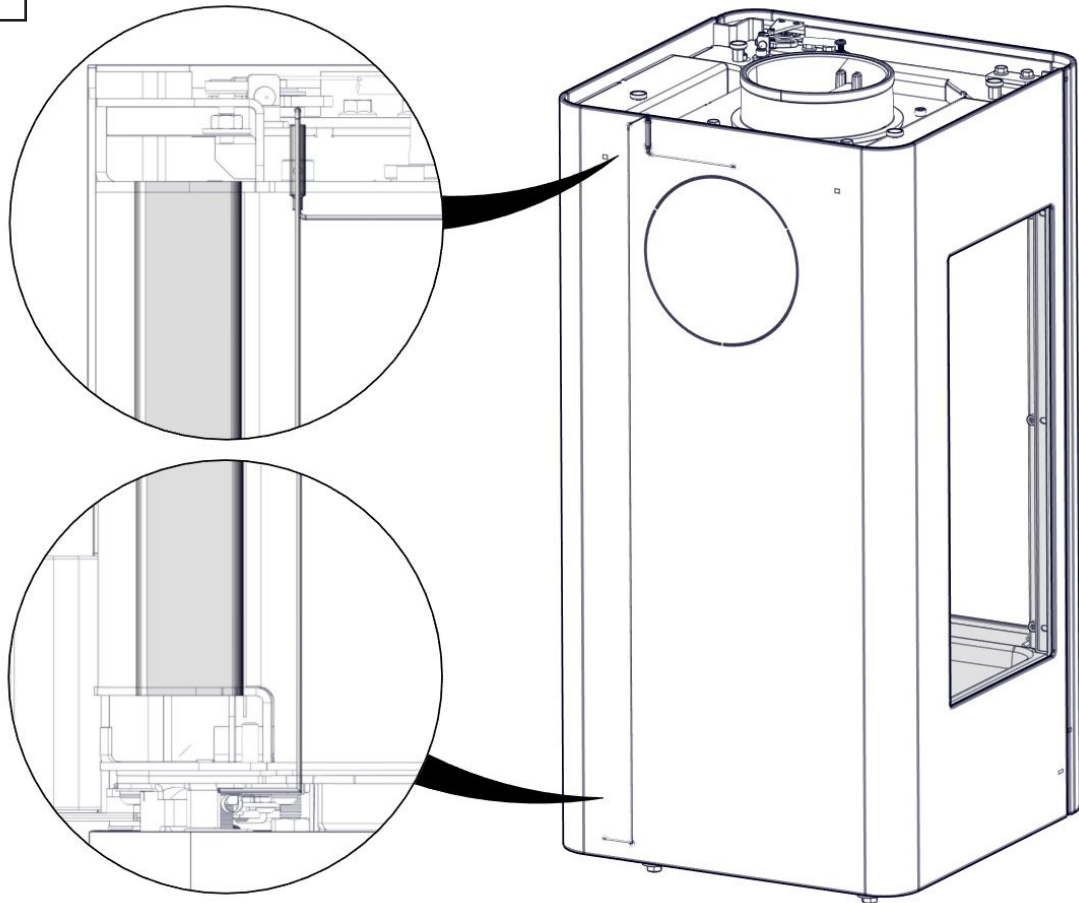

FIG 13

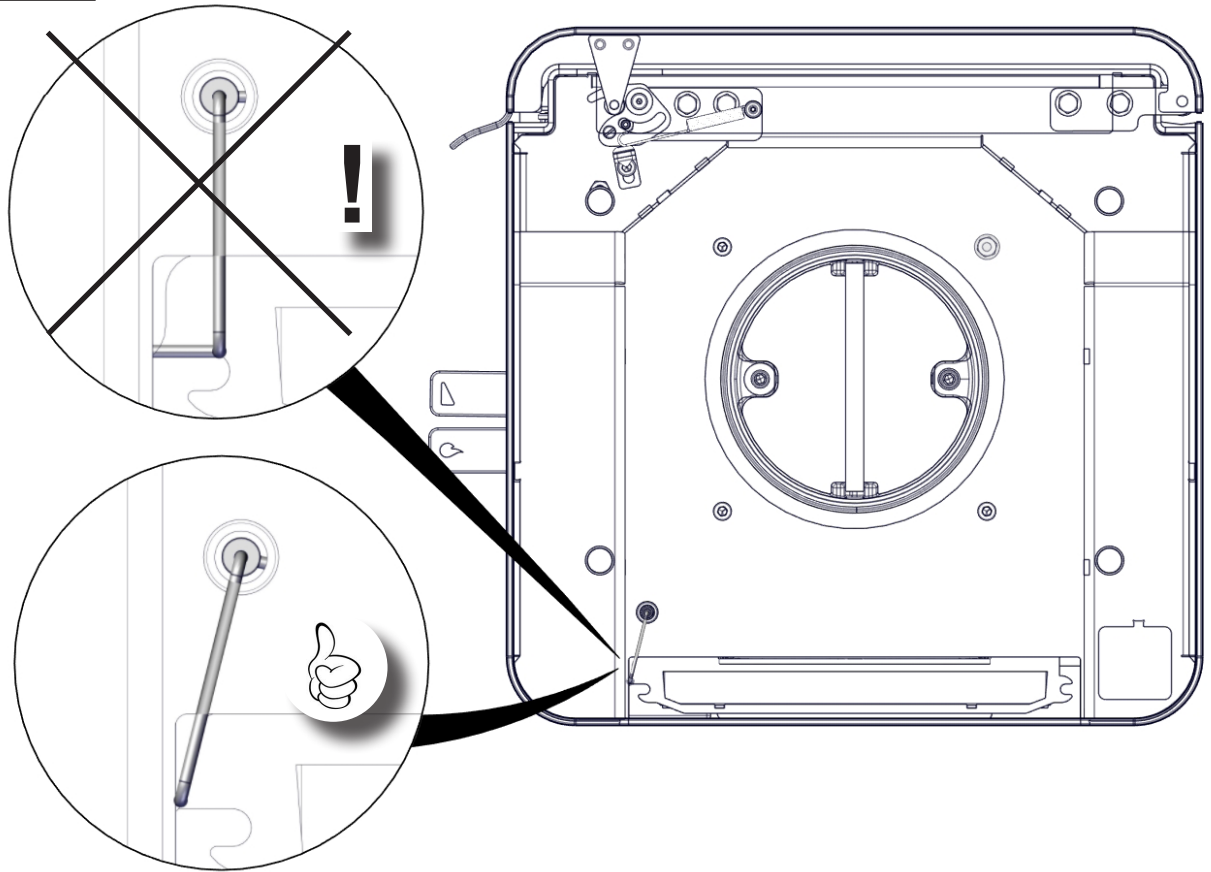

FIG14

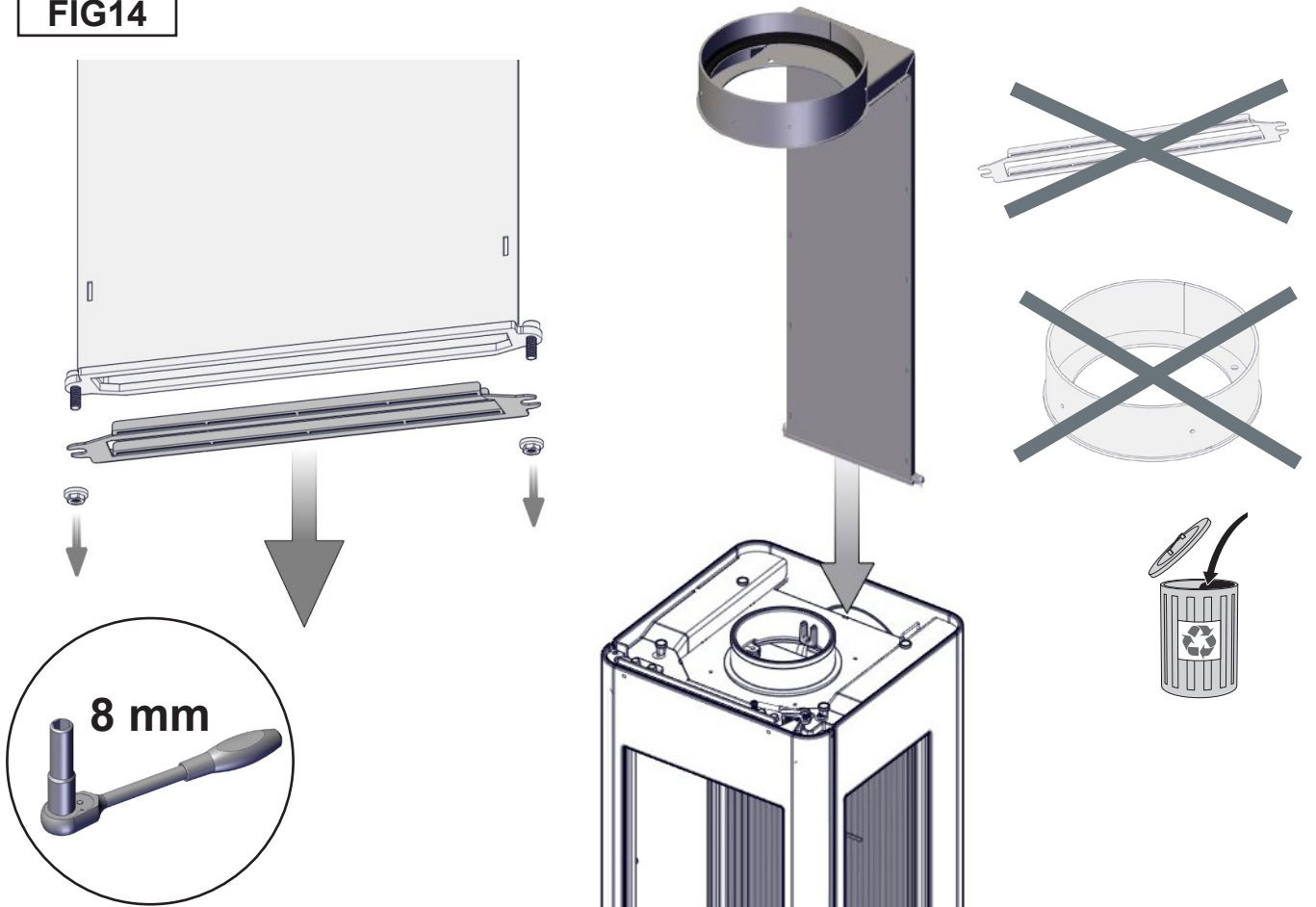

FIG 15

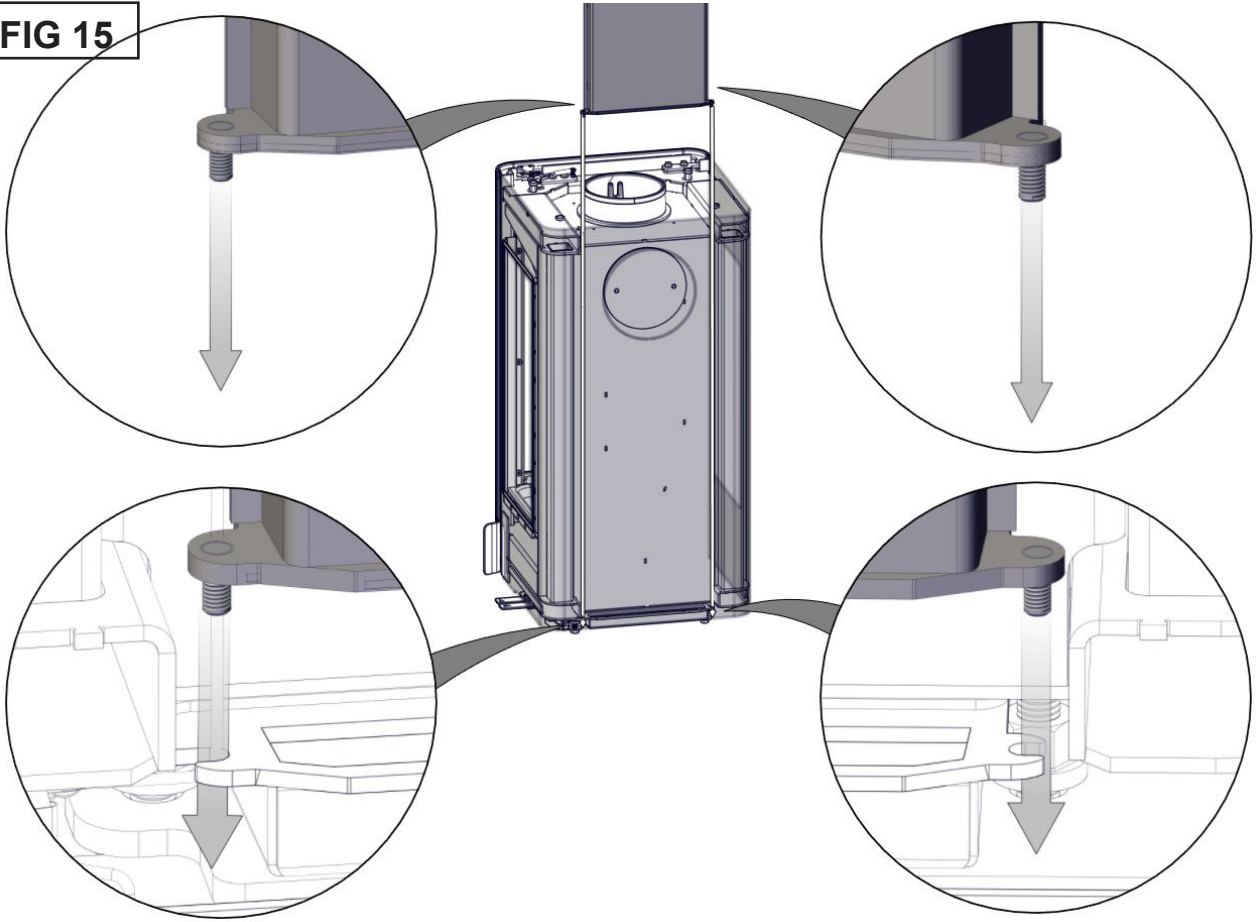

FIG 16

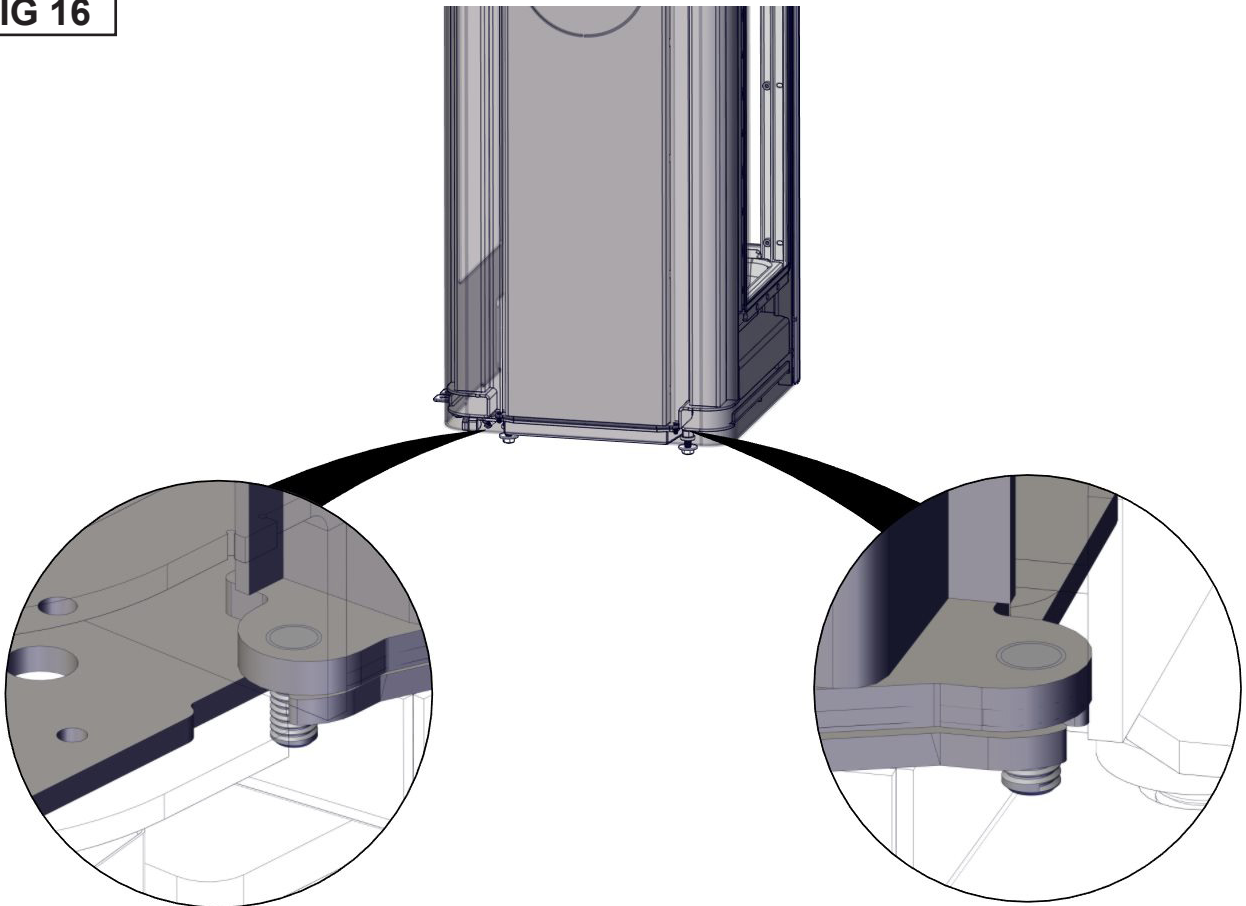

FIG 17

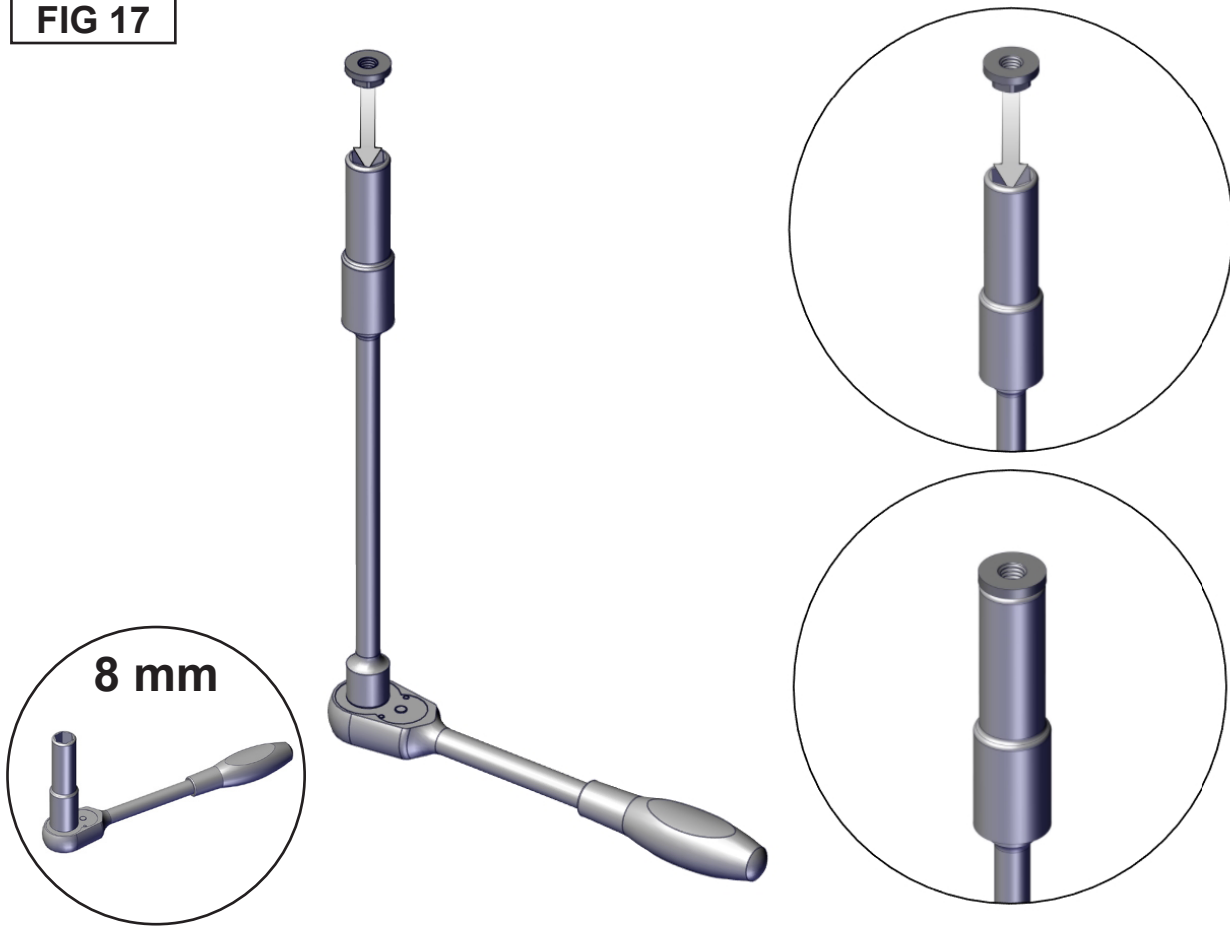

FIG 18

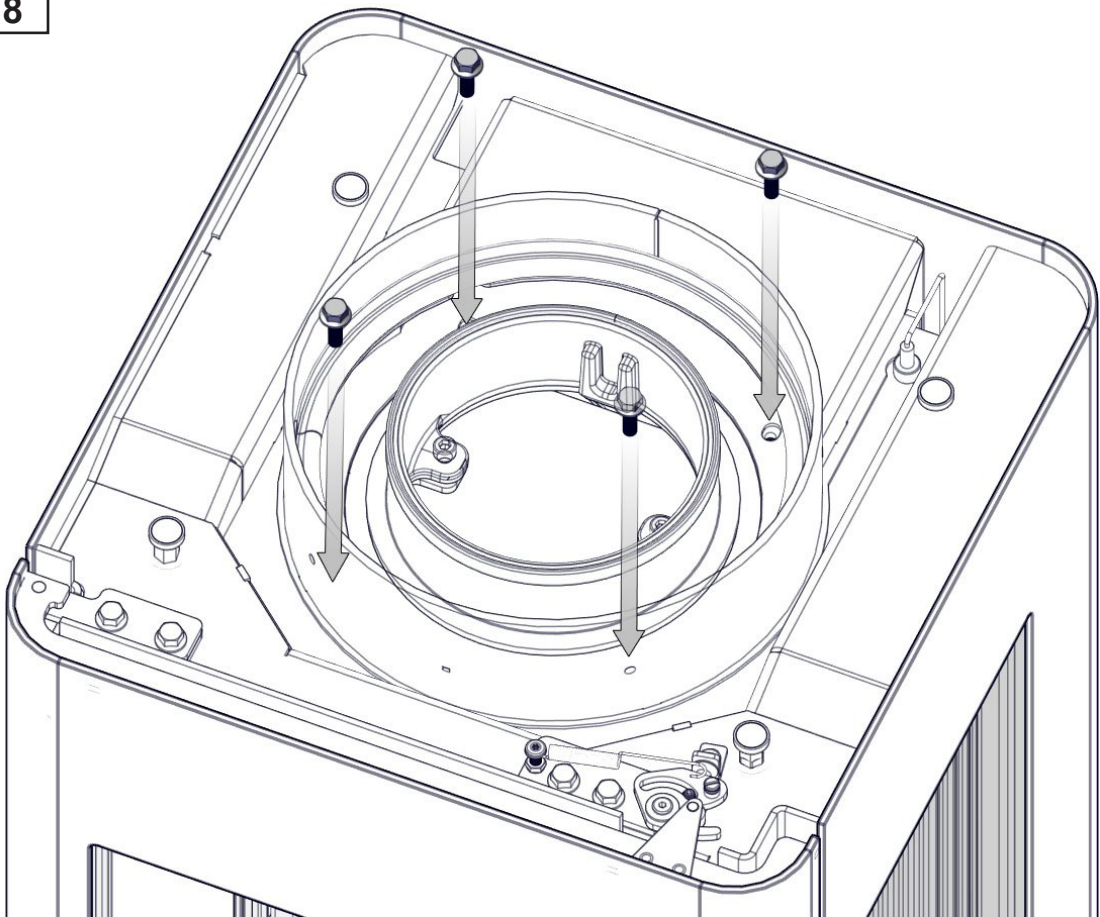

FIG19

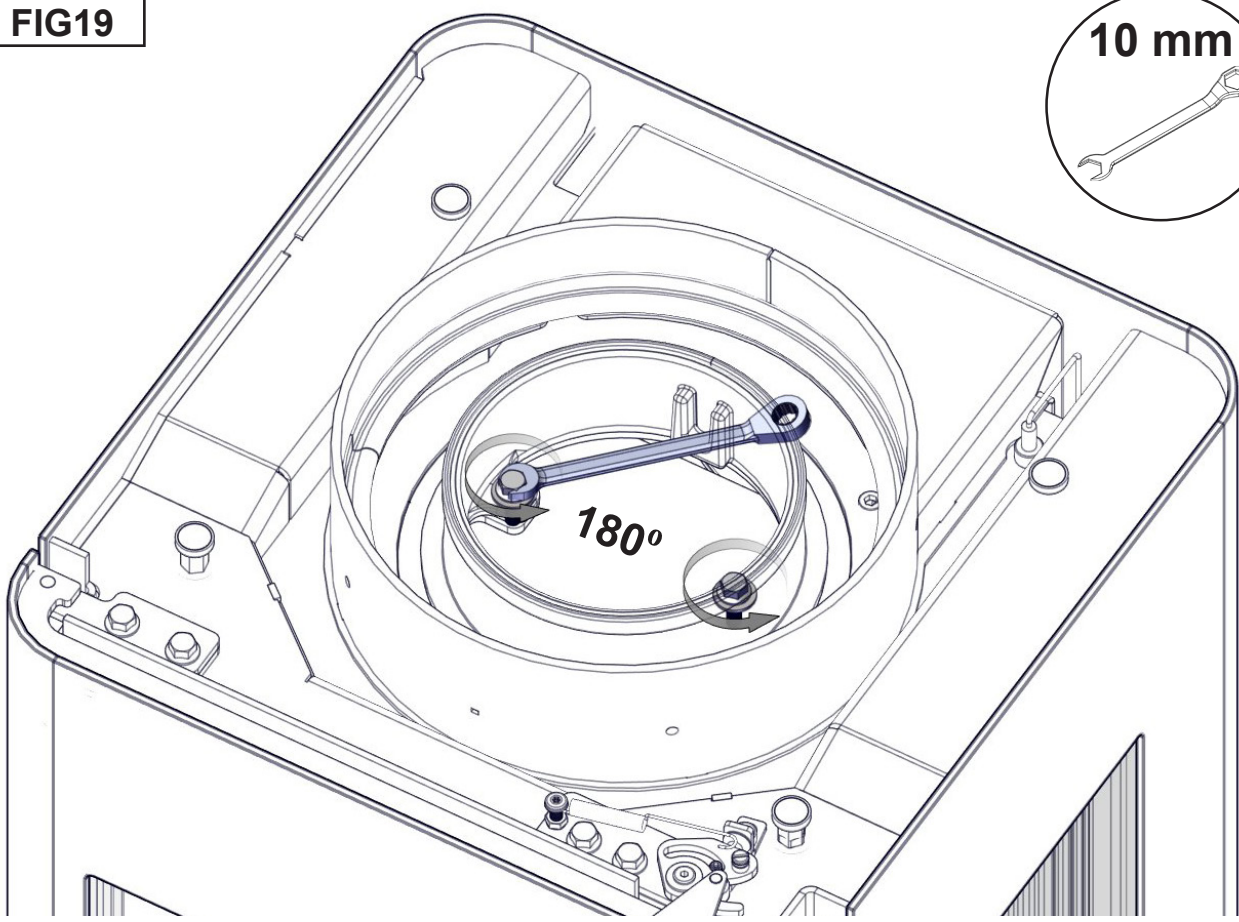

FIG 20

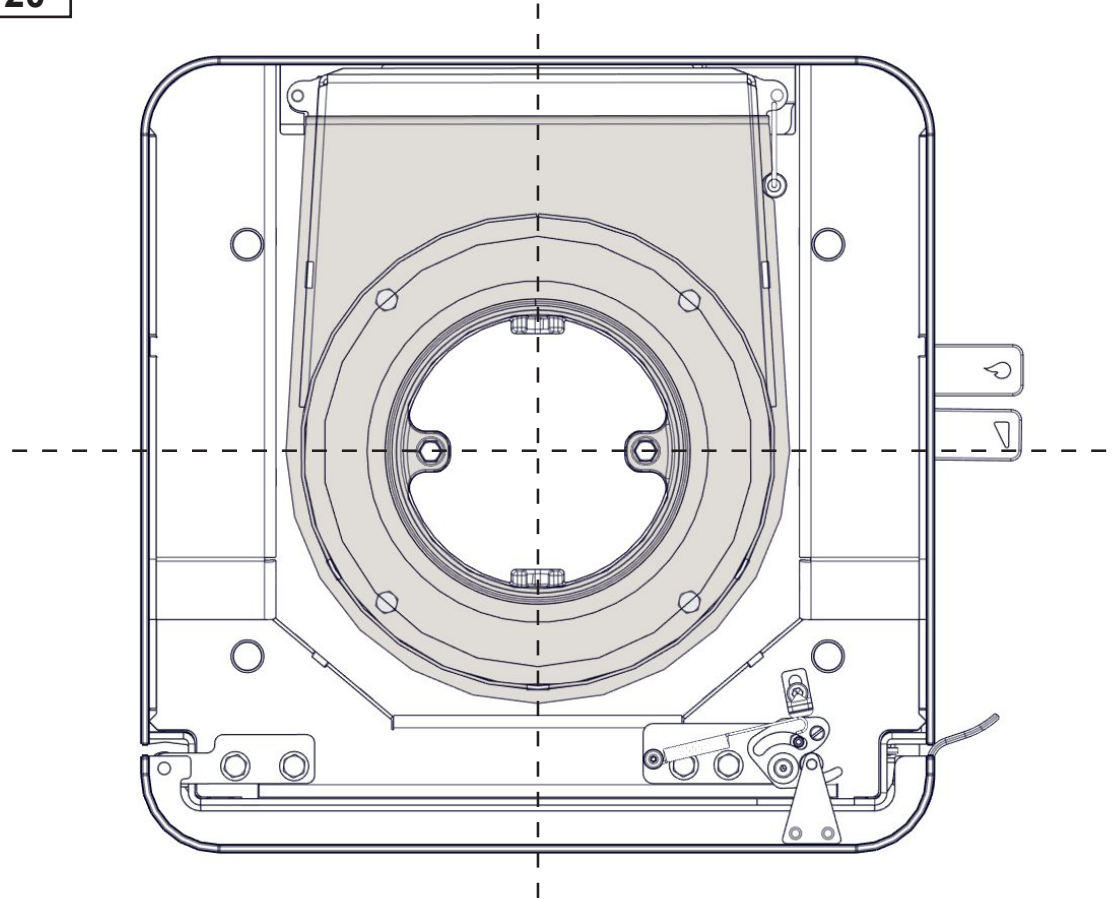

FIG 21

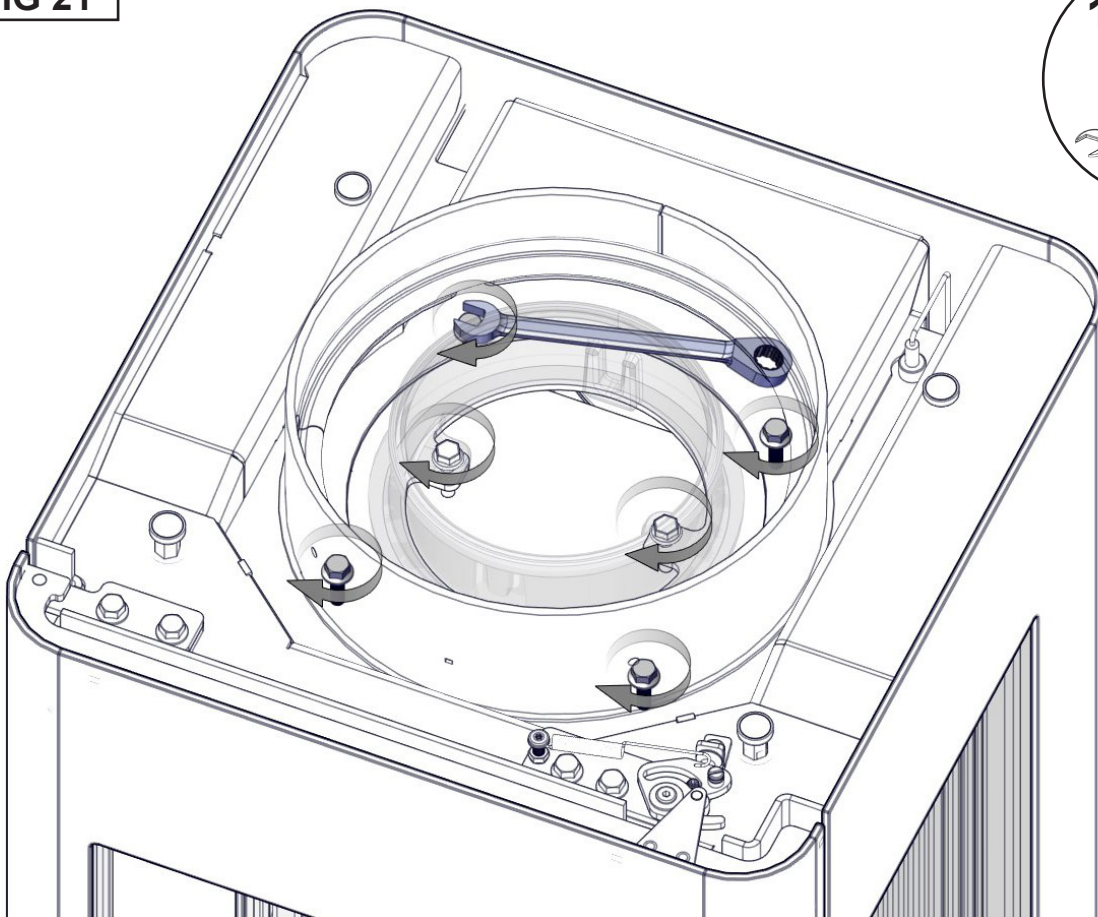

FIG 22

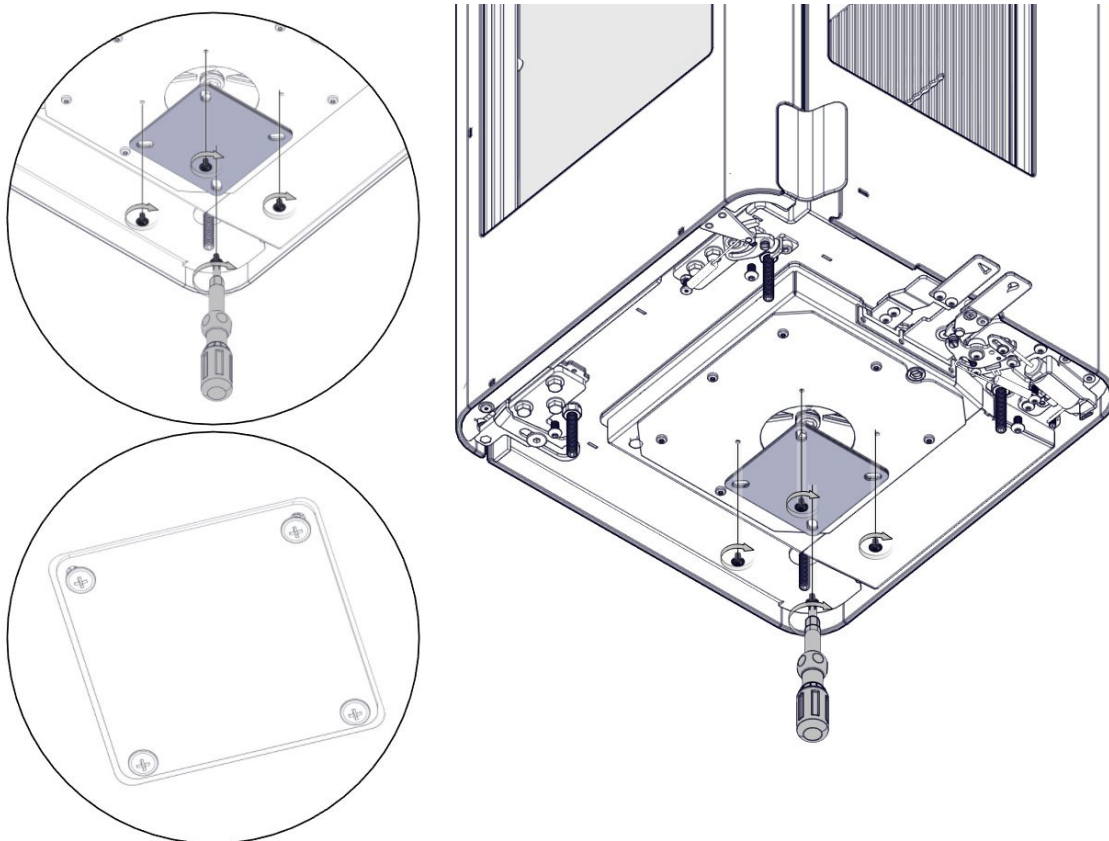

FIG 23

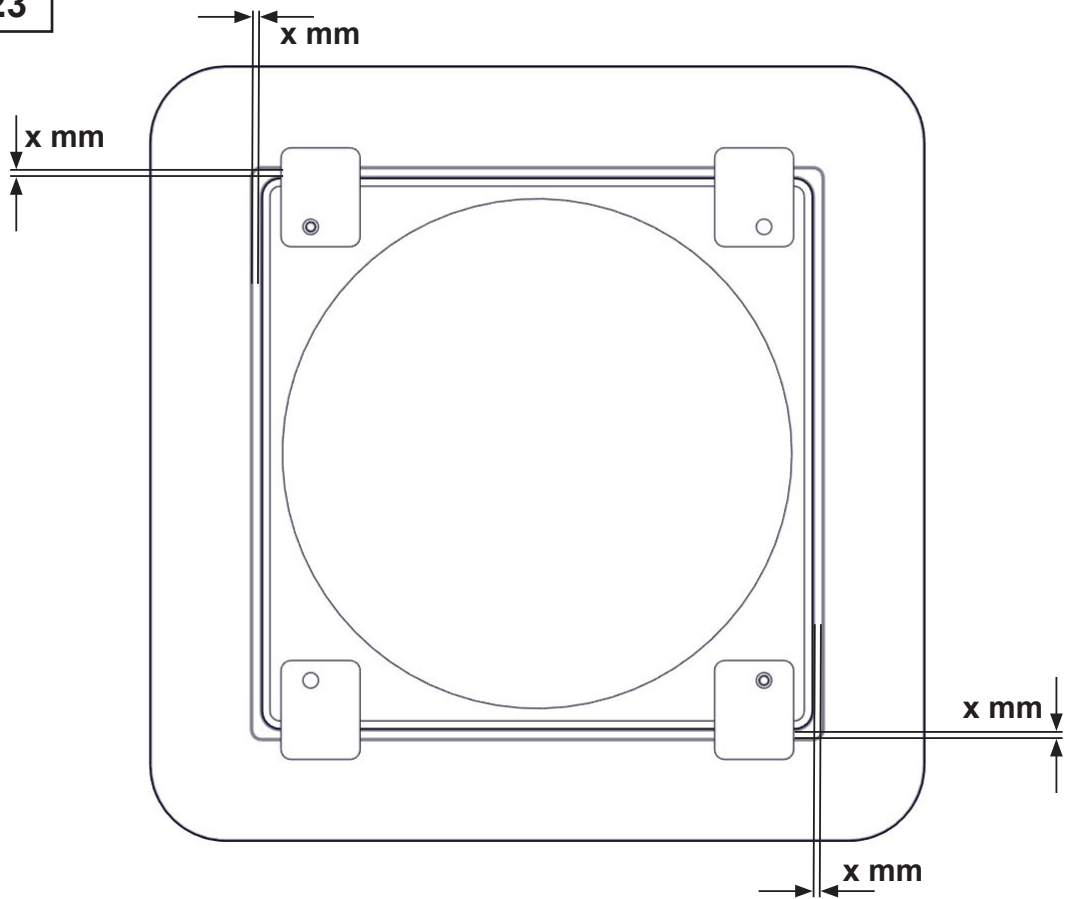

FIG 24

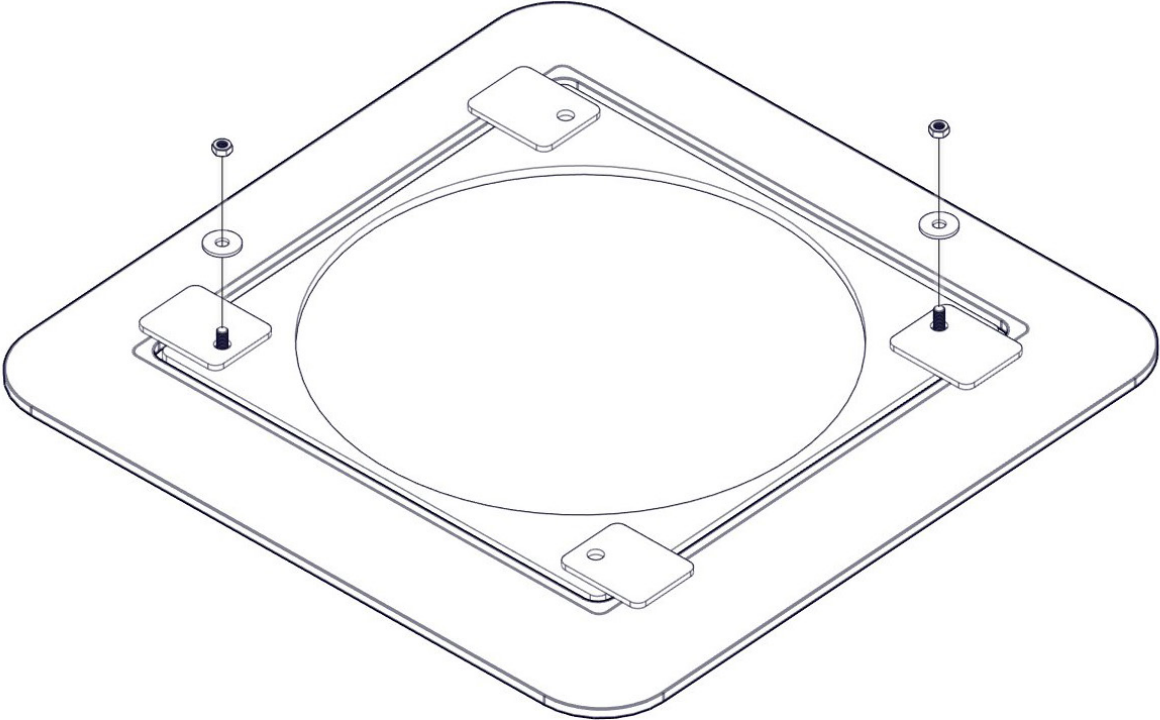

FIG 25

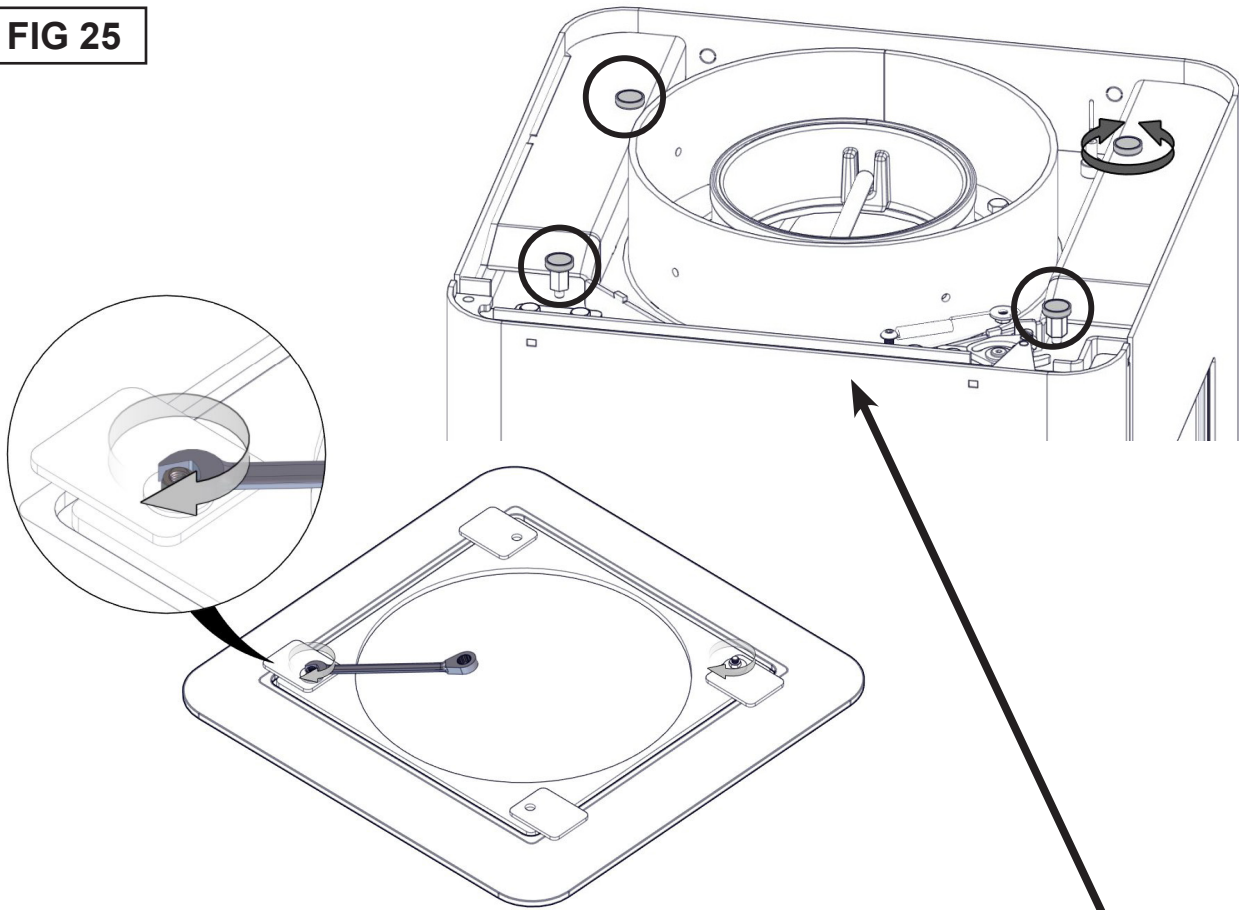

FIG 26

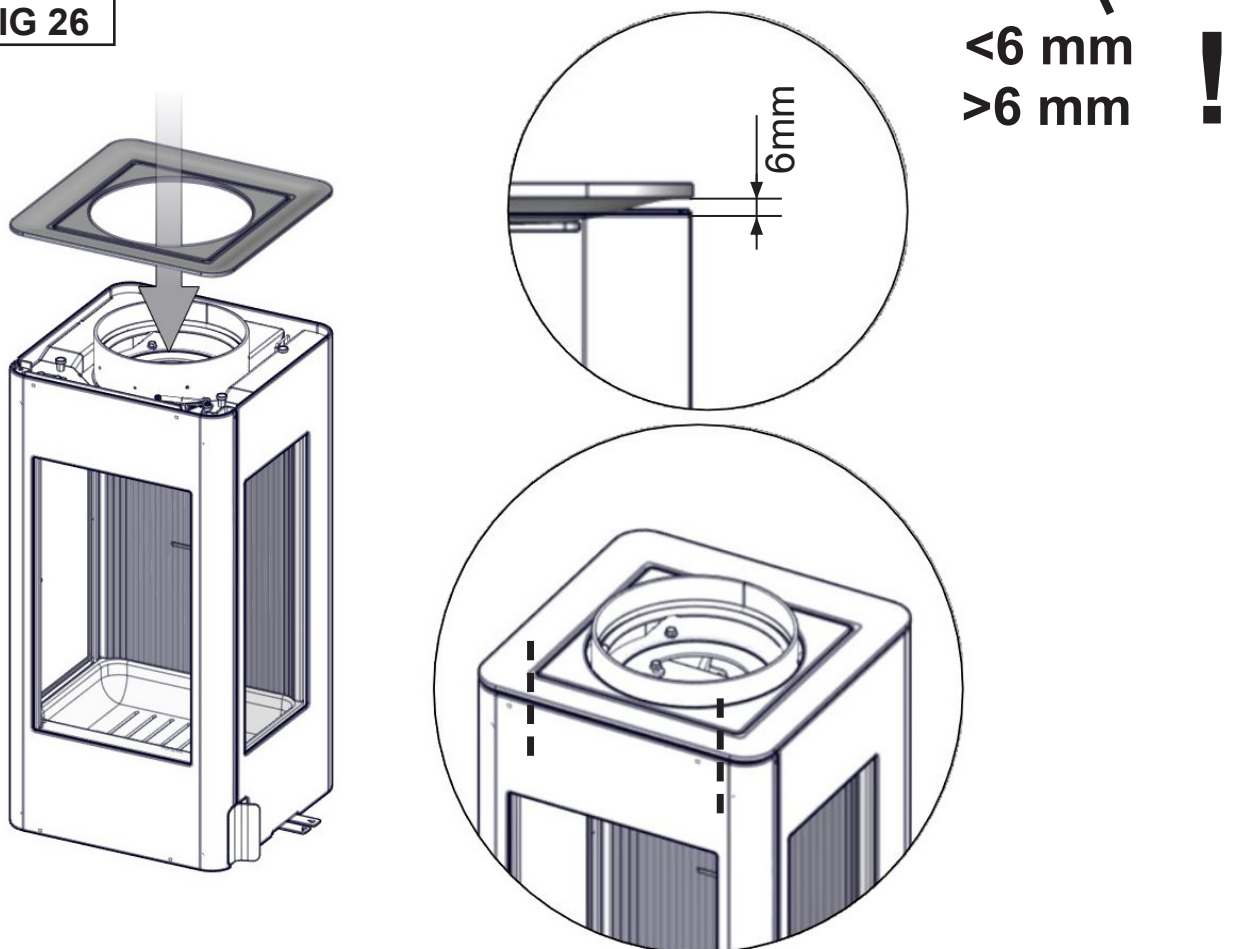

FIG 27

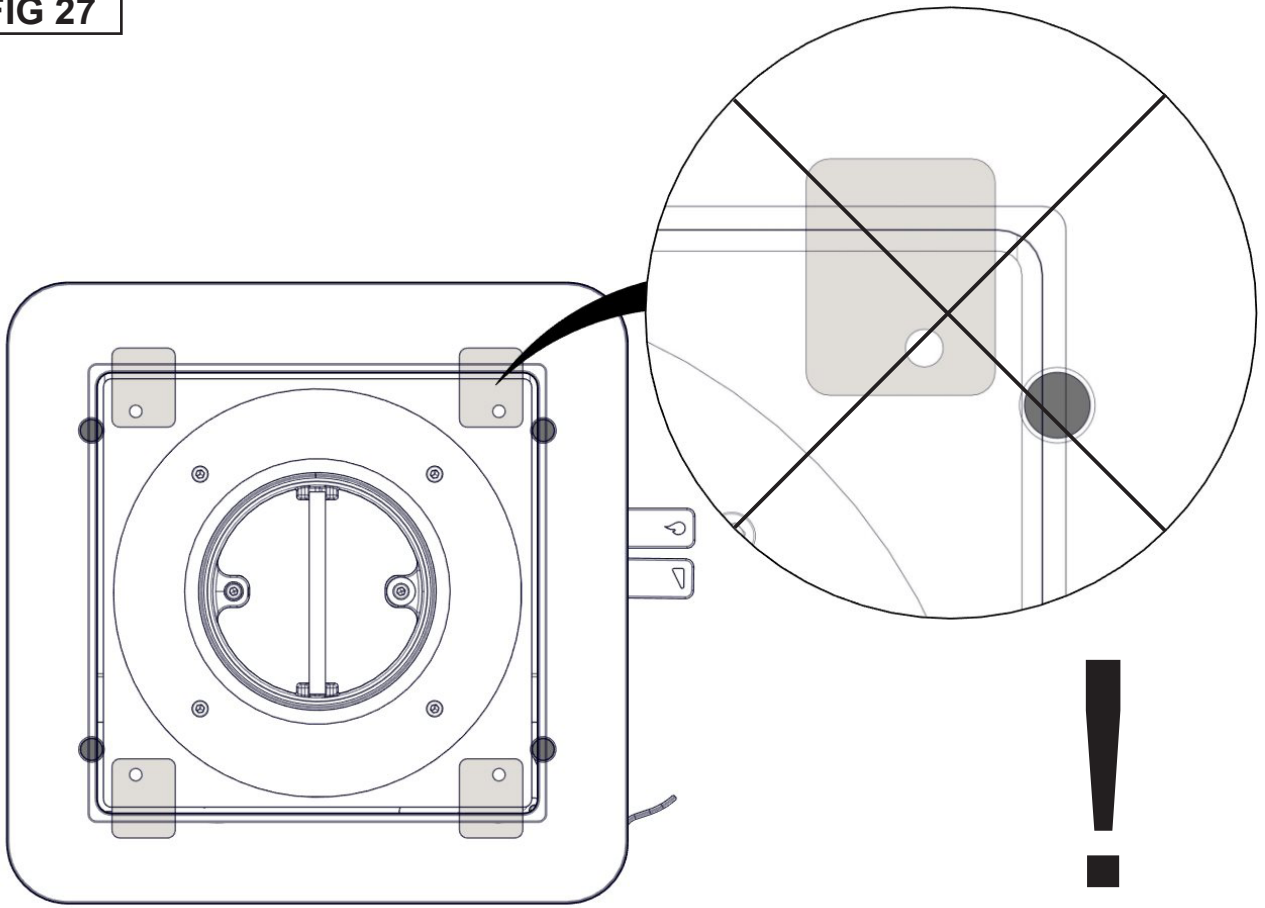

FIG 28

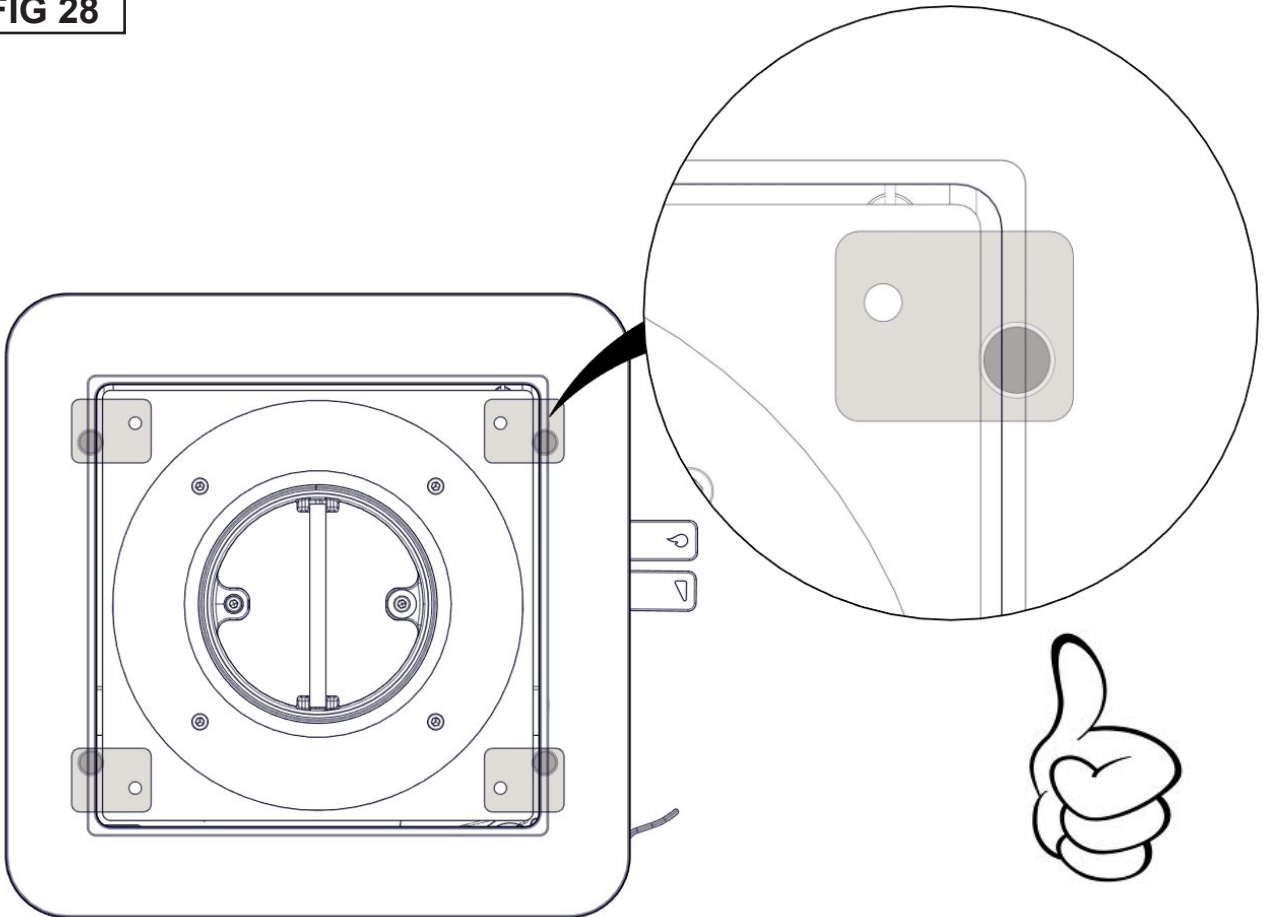

FIG 29

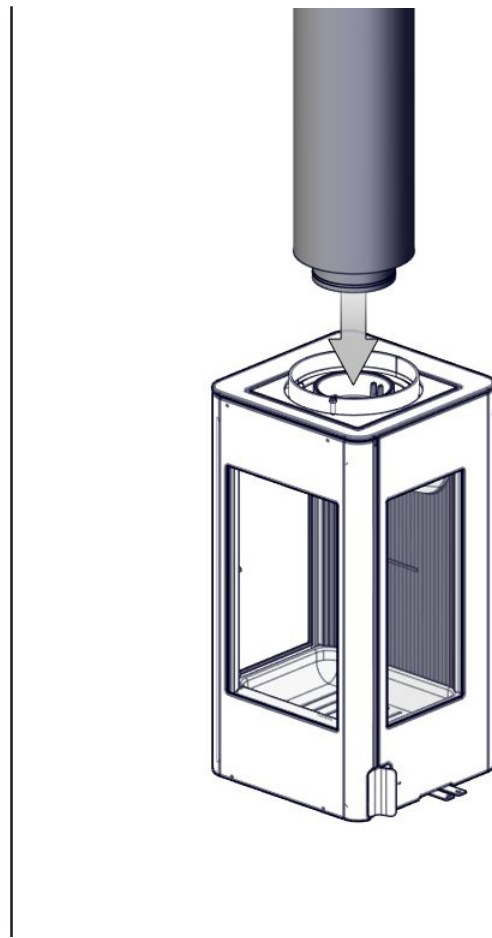
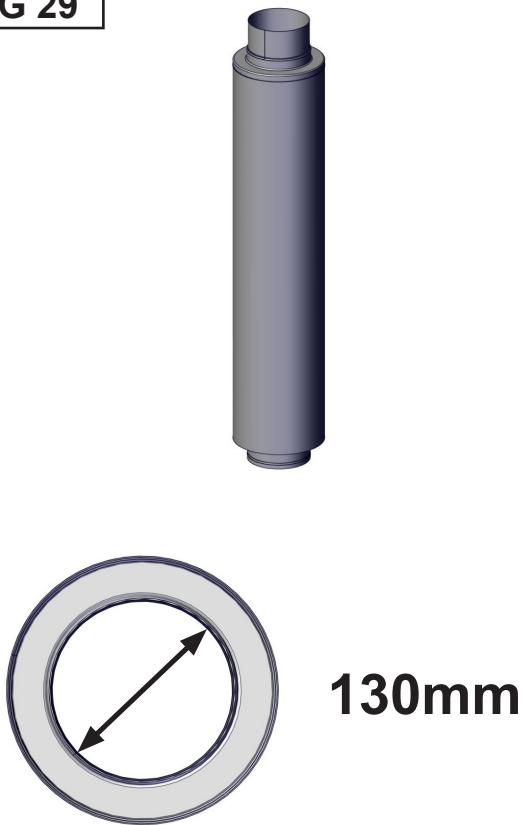

FIG 30

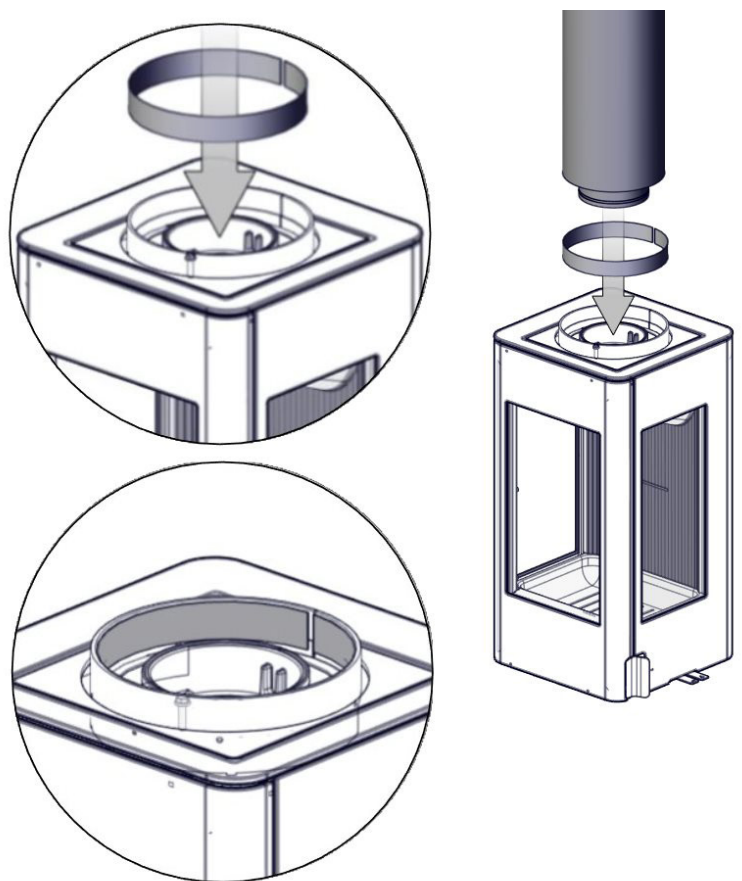
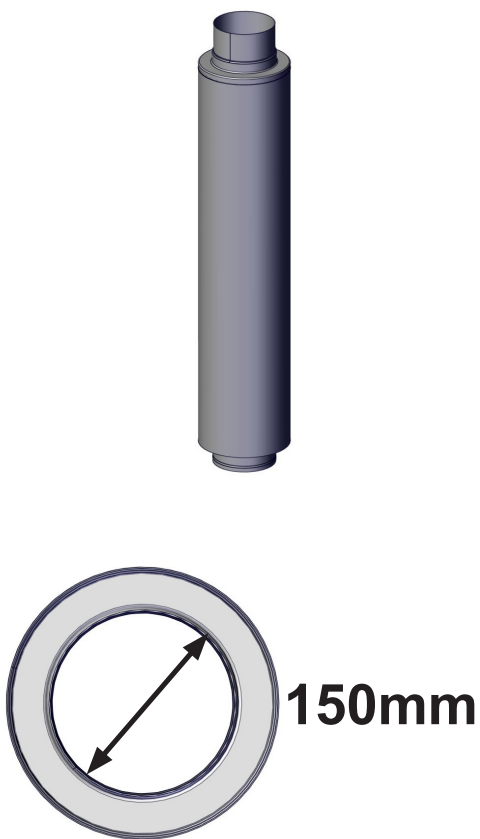

FIG 31

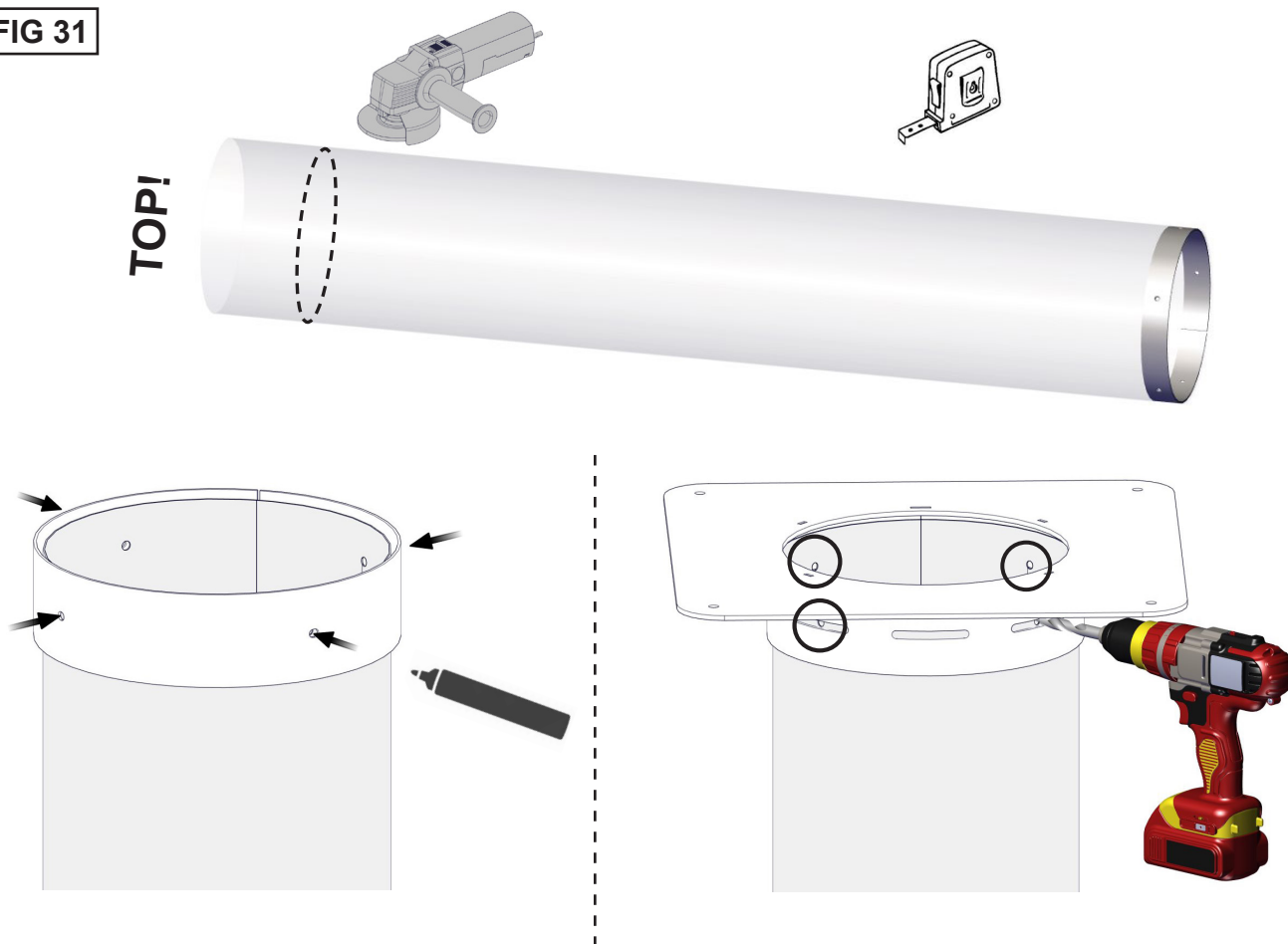
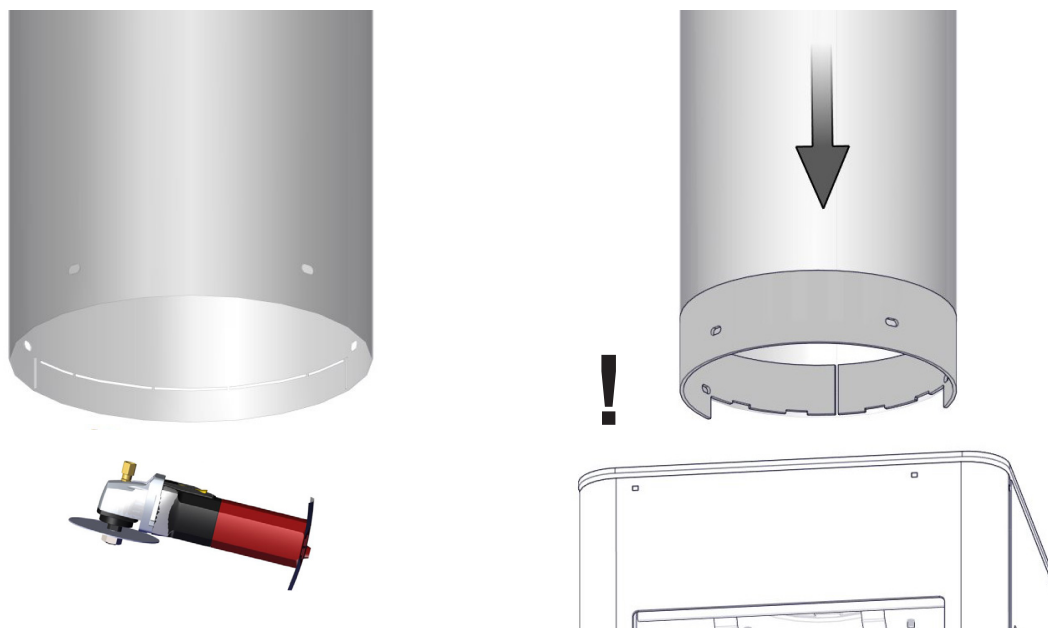

FIG 31 a



- (NO)** Vær nøye med å ikke skade de lakkerte overflatene under montasje og håndtering.
- (SE)** Var försiktig så att lackerade ytor inte skadas under montering och hantering.
- (GB)** During assembly and handling please be careful not to damage the painted surfaces.
- (FI)** Varo vaurioittamasta maalipintaa kokoamisen ja käsittelyn aikana.
- (DE)** Während der Montage und der Arbeiten darauf achten, dass die lackierten Oberflächen nicht beschädigt werden.
- (FR)** Lors du montage et de la manipulation, veillez à ne pas endommager les surfaces peintes.

FIG 32

1.

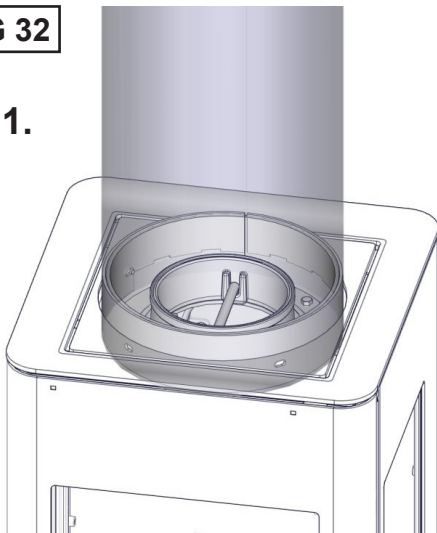

2.

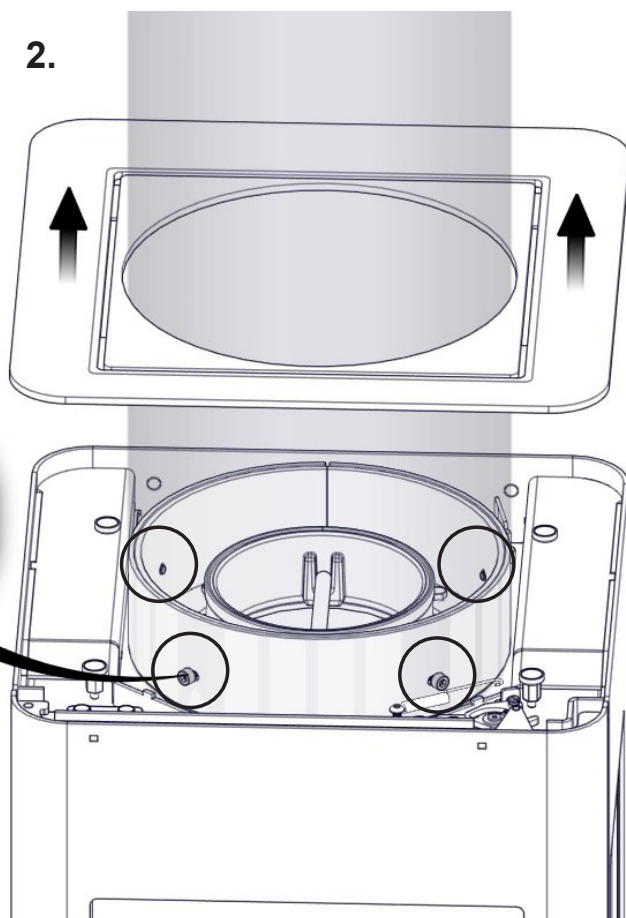

5 mm

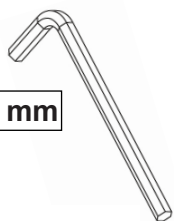

x4

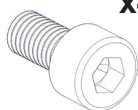
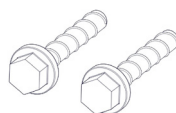

FIG 32 a

- (NO)** Veggskruer ikke inkludert
- (SE)** Väggskravar ingår ej
- (GB)** Wall screws not included
- (FI)** Seinäruuvit eivät sisälly
- (DE)** Wandschrauben sind nicht im Lieferumfang enthalten
- (FR)** Vis murales non incluses



- (NO)** Bruk veggbraketten for å stabilisere ovnen
- (SE)** Använd väggfästet för att stabilisera kaminen
- (GB)** Use the wall bracket to stabilize the stove
- (FI)** Käytä seinäkiinnikettä kamiinan vakauttamiseen
- (DE)** Verwenden Sie die Wandhalterung, um den Ofen zu stabilisieren
- (FR)** Installer le support de fixation pour stabiliser le poêle

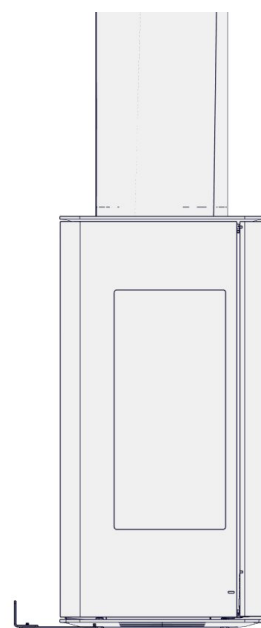
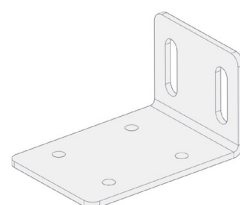

FIG 33

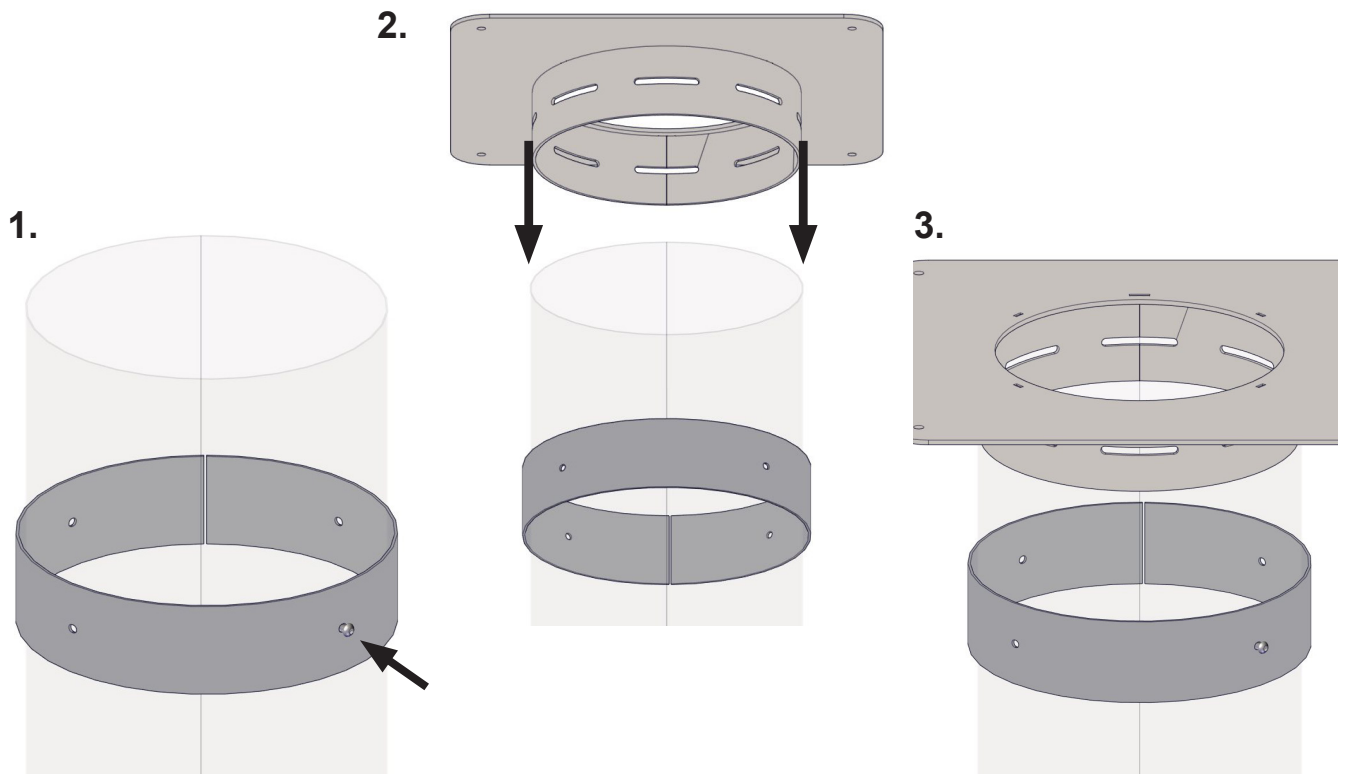

FIG 33 a

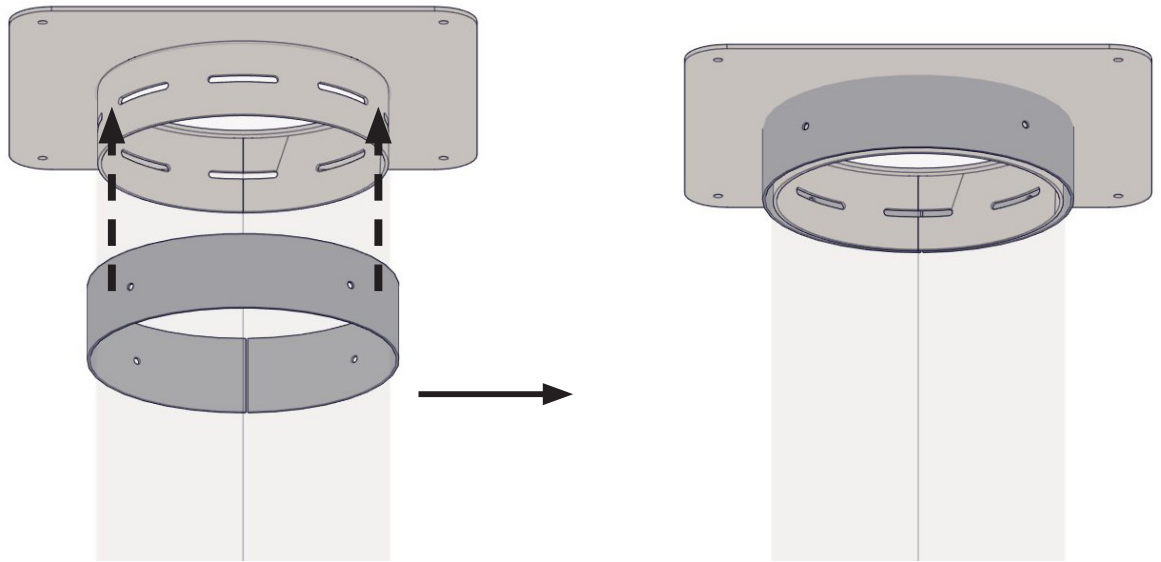
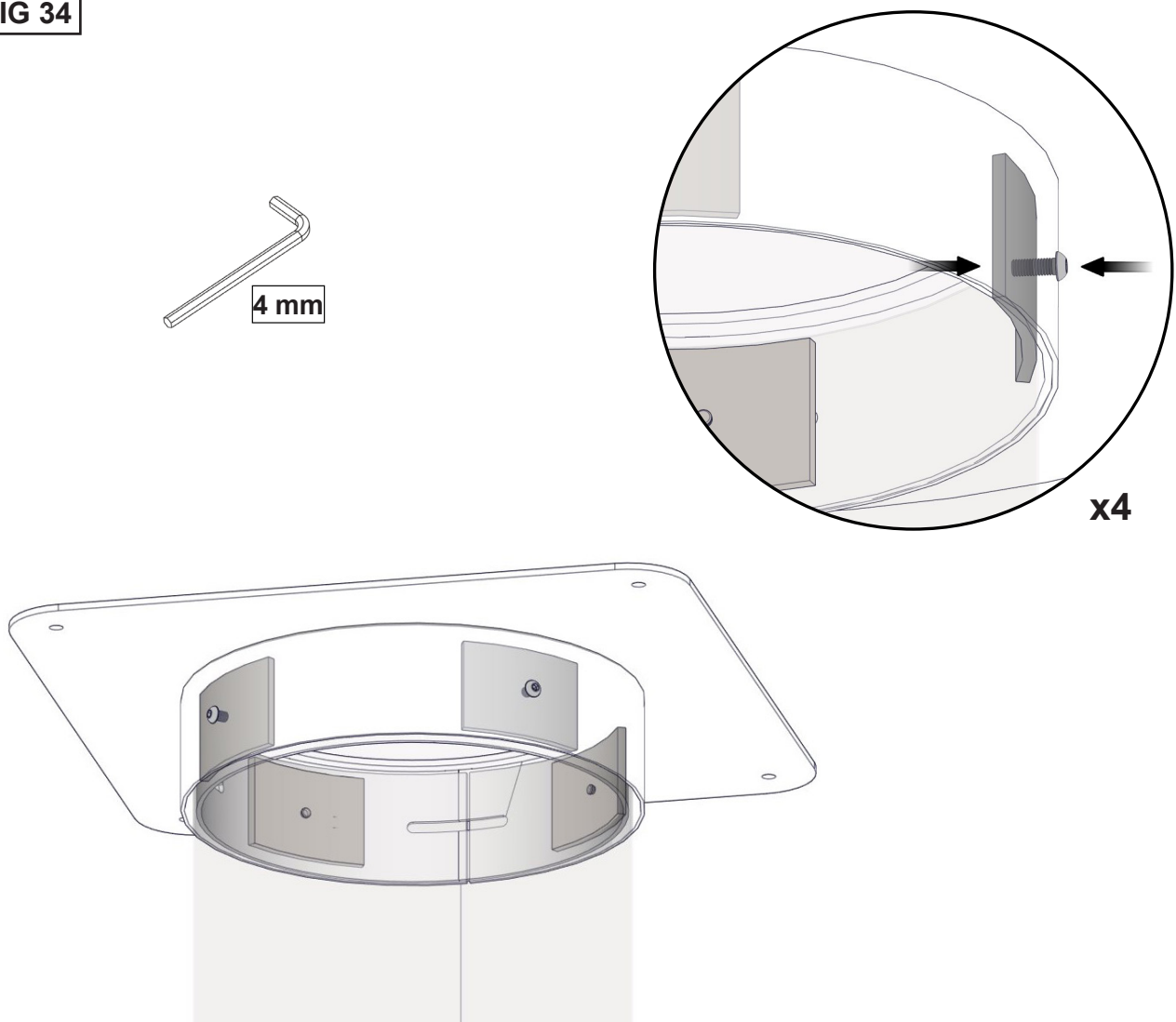
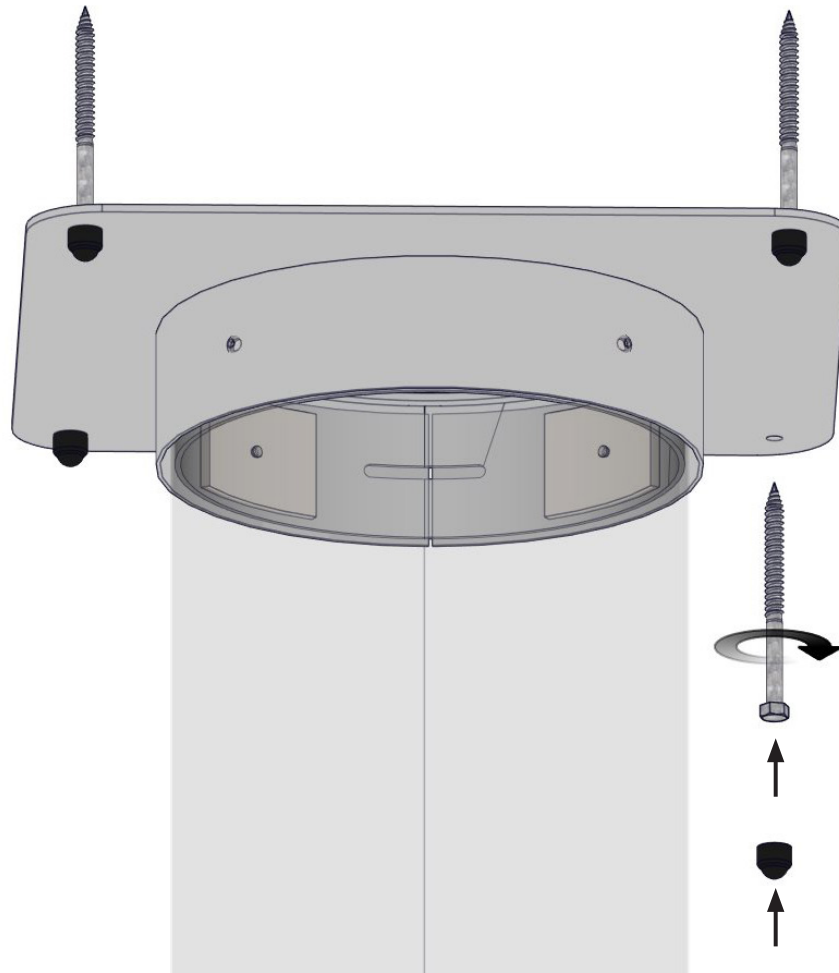

FIG 34



- NO** Se til at boltene plasseres i midten av de avlange hullene i takplaten. Da kan man justere vinkelen på ovnen med 15 grader i hver retning etter at takplaten er festet til taket.
- SE** Försäkra dig om att skruvarna är positionerade i mitten av de ovala hålen i takstosen (på så sätt kan kaminens vinkel justeras 15 grader i varje riktning efter att takstosen har installerats i taket.
- GB** Make sure the bolts are placed in the middle of the prolonged bean-shaped holes in the ceiling collar. This will allow you to adjust the angle of the stove with 15 degrees in each direction after the ceiling collar has been fastend to the ceiling.
- FI** Varmista, että ruuvit ovat kattokauluksen soikeiden reikien keskellä. Näin voit säätää takan kulmaa 15 astetta kaikkiin suuntiin, kun kattokaulus on kiinnitetty kattoon.
- DE** Sicherstellen, dass die Bolzen in der Mitte der ovalen Langlöcher im Deckenkragen eingesetzt werden. Damit ist es möglich, den Winkel des Kaminofens um 15 Grad in jede Richtung anzupassen, nachdem der Deckenkragen an der Decke befestigt wurde.
- FR** Assurez-vous que les boulons sont placés au milieu des trous oblongues dans le collet de plafond. Cela vous permettra d'ajuster l'angle du poêle de 15 degrés dans chaque direction une fois que le collet de plafond a été fixé à ce dernier.

FIG 35



- NO** De vedlagte treskruene er kun beregnet for massive trebjelker med mindstemål 150 x 50 mm. Forbor $\varnothing 6$ mm huller før skruene skrues inn. Skjul så skruene med medfølgende plastkapper.
- SE** Medföljande skruvar är avsedda endast för solida träbalkar med min.-mått 150 mm (höjd) och 50 mm (bredd). Förborra hål ($\varnothing 6$ mm) innan du skruvar i medföljande skruvar (placera också medföljande plastlock över skruvarnas ände).
- GB** The supplied bolts are only intended for solid wooden beams measuring at least 150mm in height and 50mm in width. Pre-drill $\varnothing 6$ mm holes before applying the supplied bolts and capping them at the end with the supplied plastic caps.
- FI** Mukana toimitetut ruuvit on tarkoitettu puupalkkeihin, joiden korkeus on vähintään 150 mm ja leveys 50 mm. Esiporaa $\varnothing 6$ mm reiät ennen ruuvien asennusta ja suojaa ruuvien päät mukana toimitetuilla muovitulpilla.
- DE** Die mitgelieferten Bolzen sind nur für massive Holzbalken mit einem Mindestmaß von 150 mm (Höhe) und 50 mm (Breite) geeignet. Es sollten Löcher mit $\varnothing 6$ mm vorgebohrt werden, bevor die mitgelieferten Bolzen eingesetzt und schließlich mit den mitgelieferten Kunststoffkappen abgedeckt werden.
- FR** Les boulons fournis sont uniquement prévus pour des poutres en bois solides mesurant au moins 150 mm de hauteur et 50 mm de largeur. Percer des trous de $\varnothing 6$ mm avant d'appliquer les boulons fournis et les recouvrir à l'aide des bouchons en plastique fournis.

FIG 36

1.

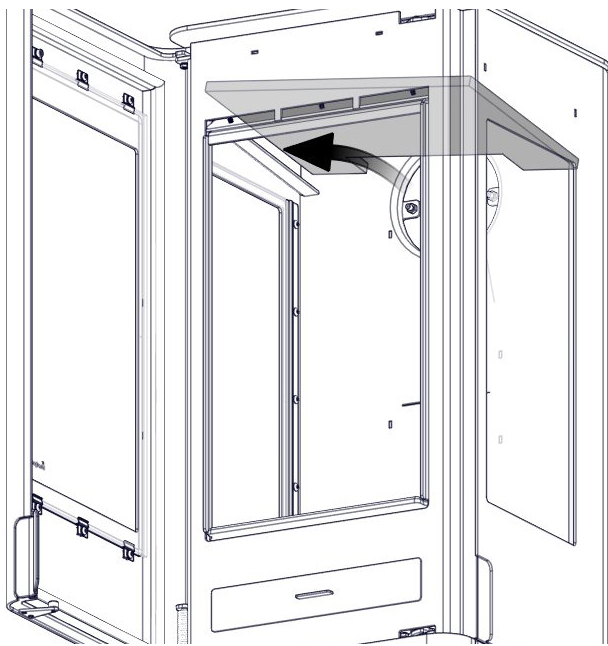

2.

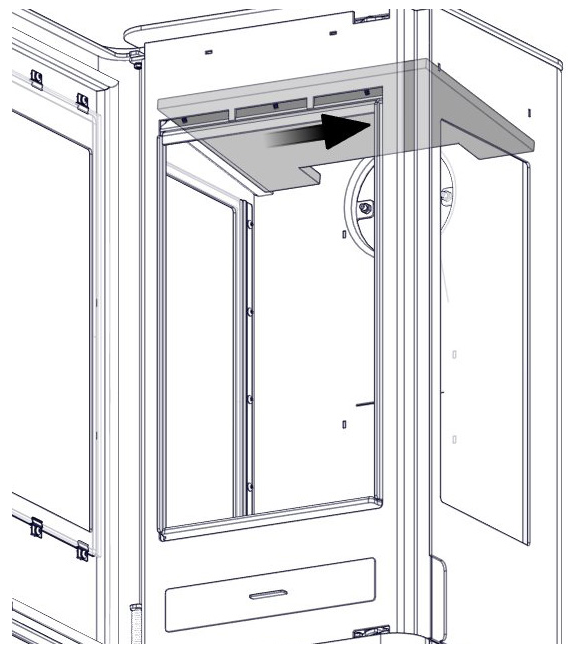
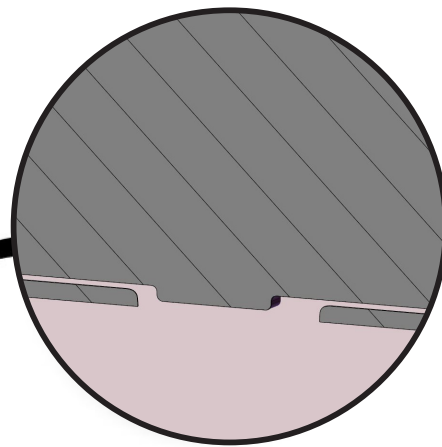
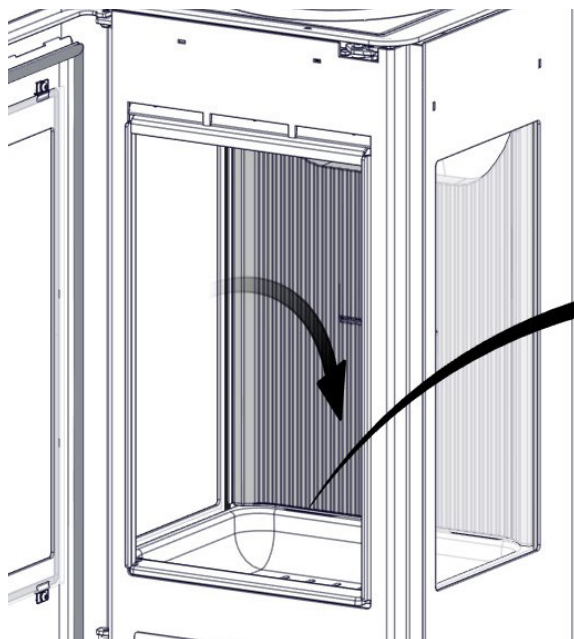

FIG 37

YoU Ceiling - Thermotte

1.



2.

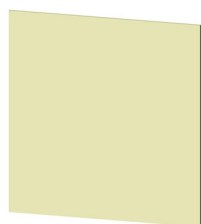

Cardboard 37x37

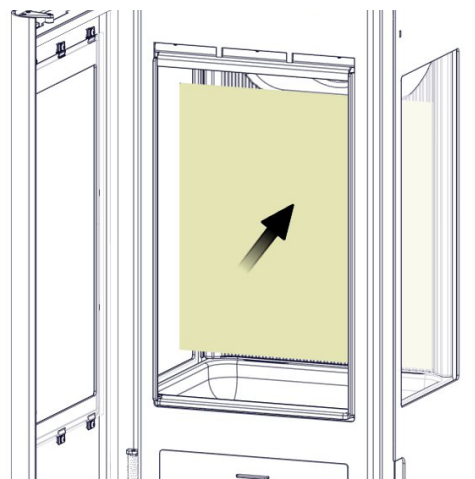
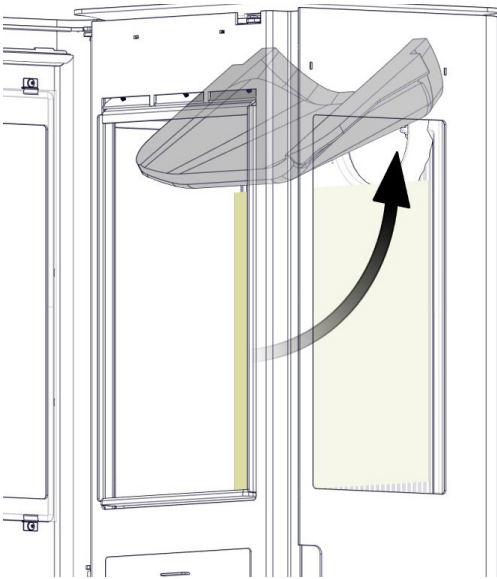
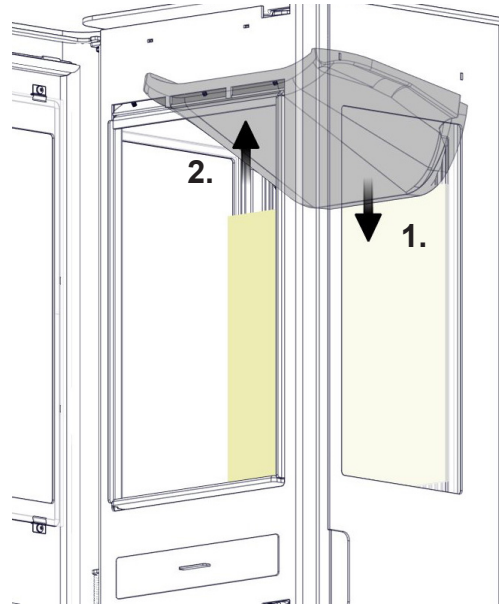

FIG 38

1.



2.



3.

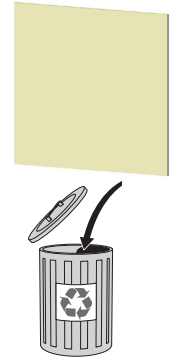

FIG 38 a

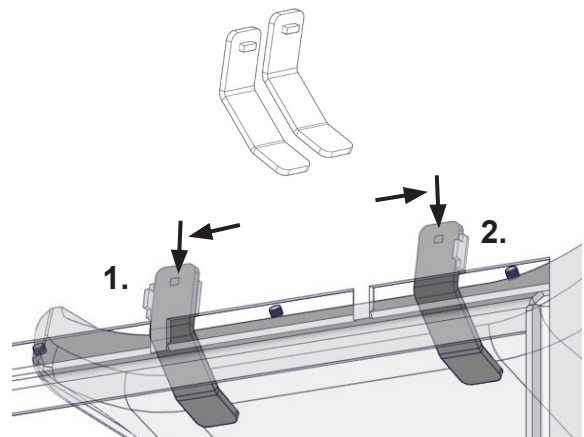
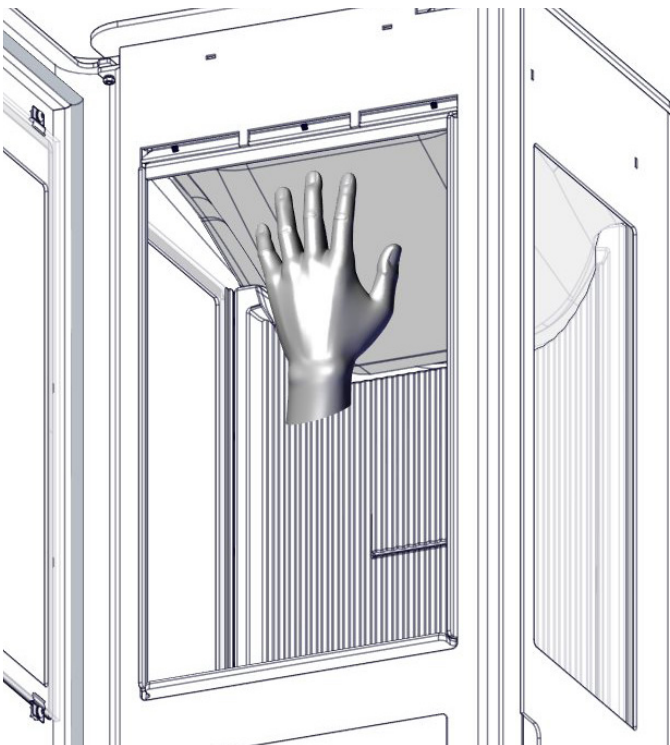

FIG 39

Stay open door

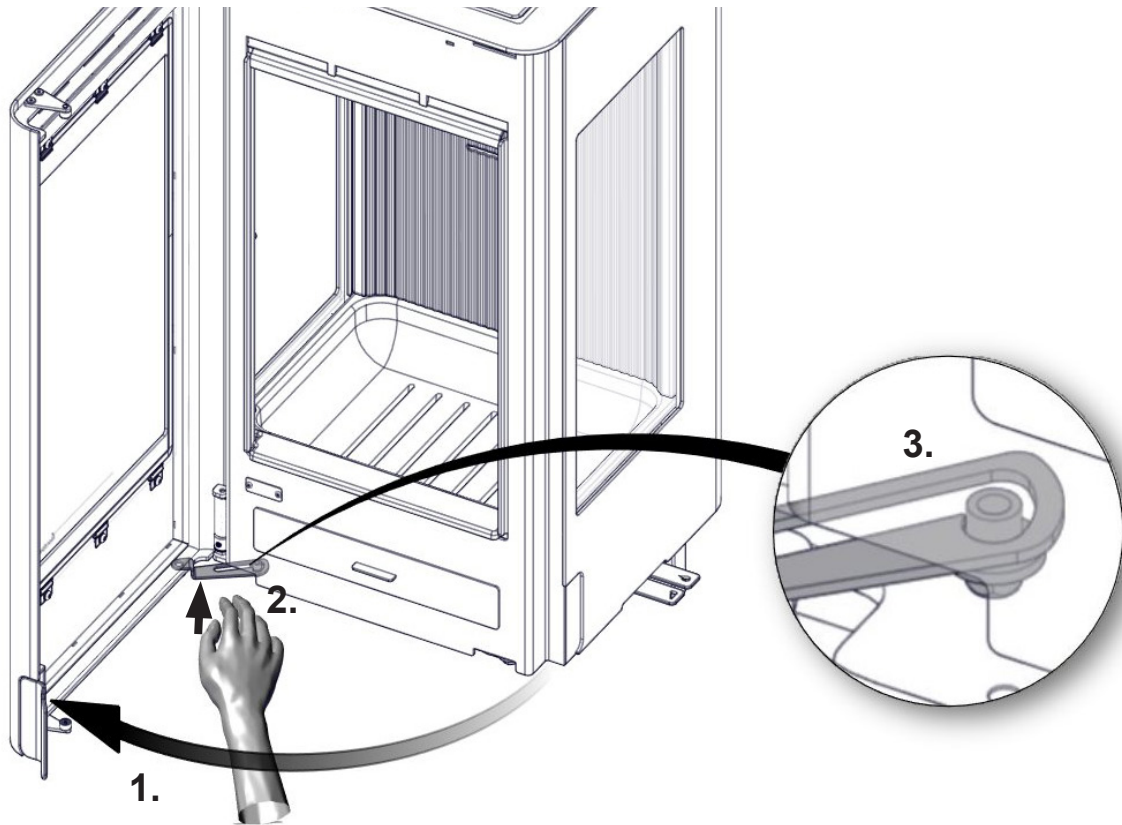

FIG 39 a

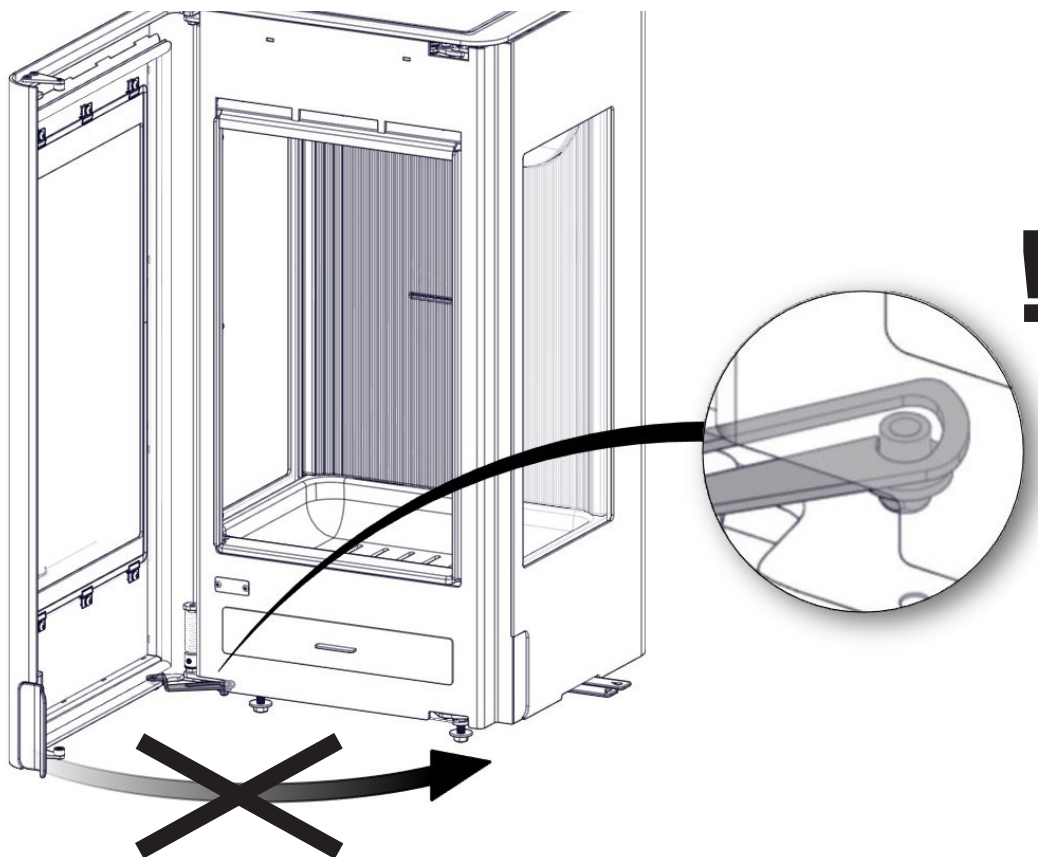

FIG 39 b

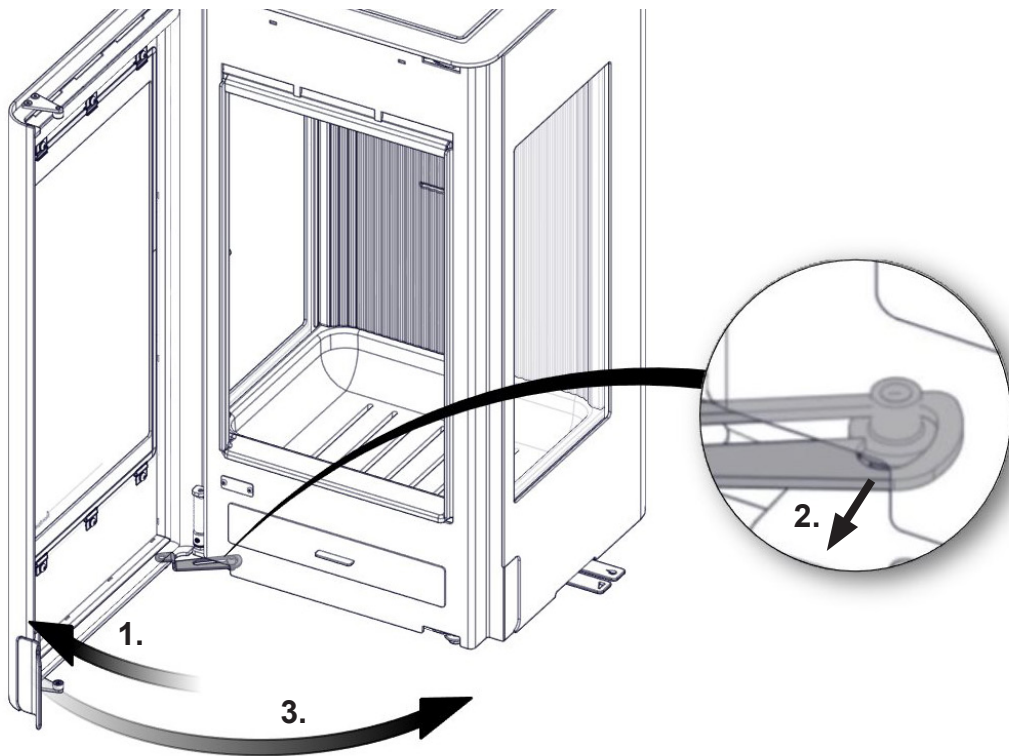

FIG 40

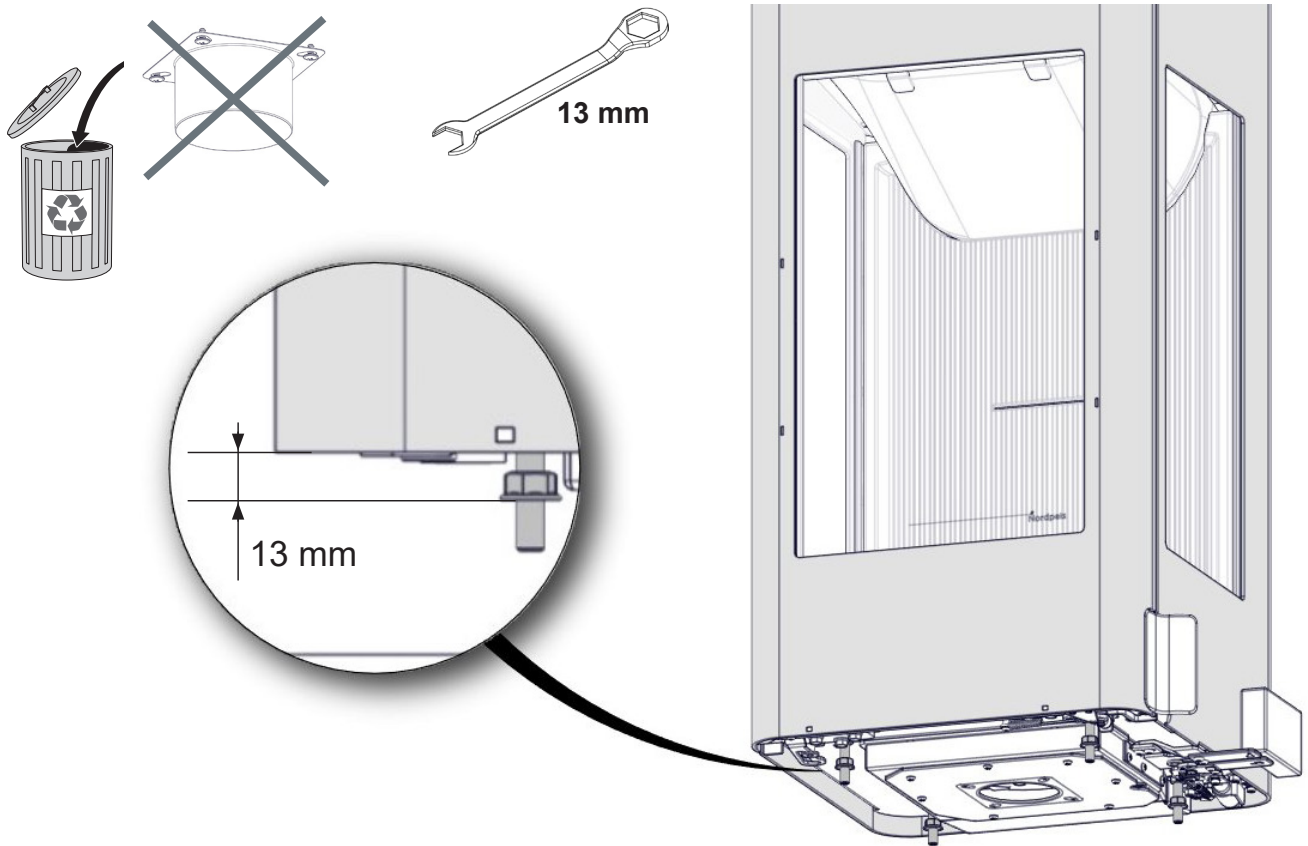

FIG 40 a

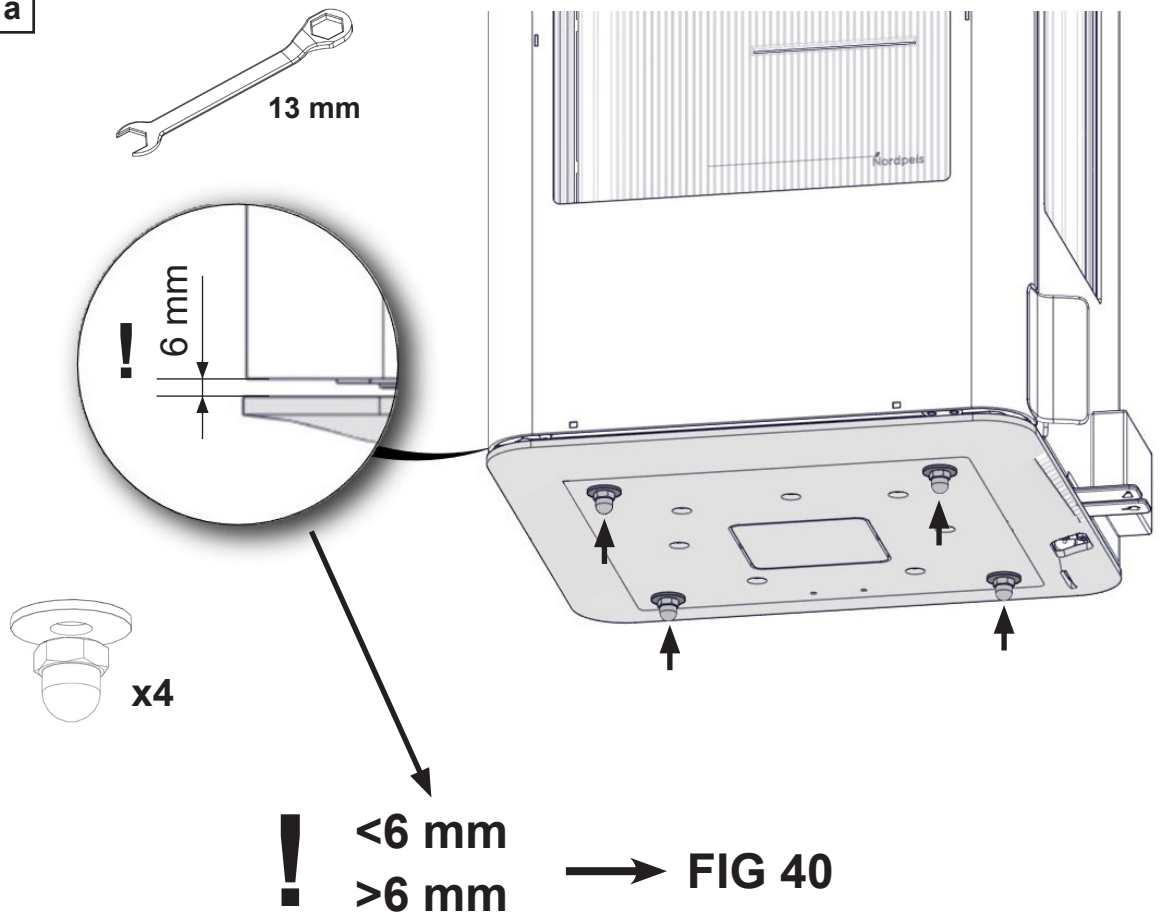

FIG 41

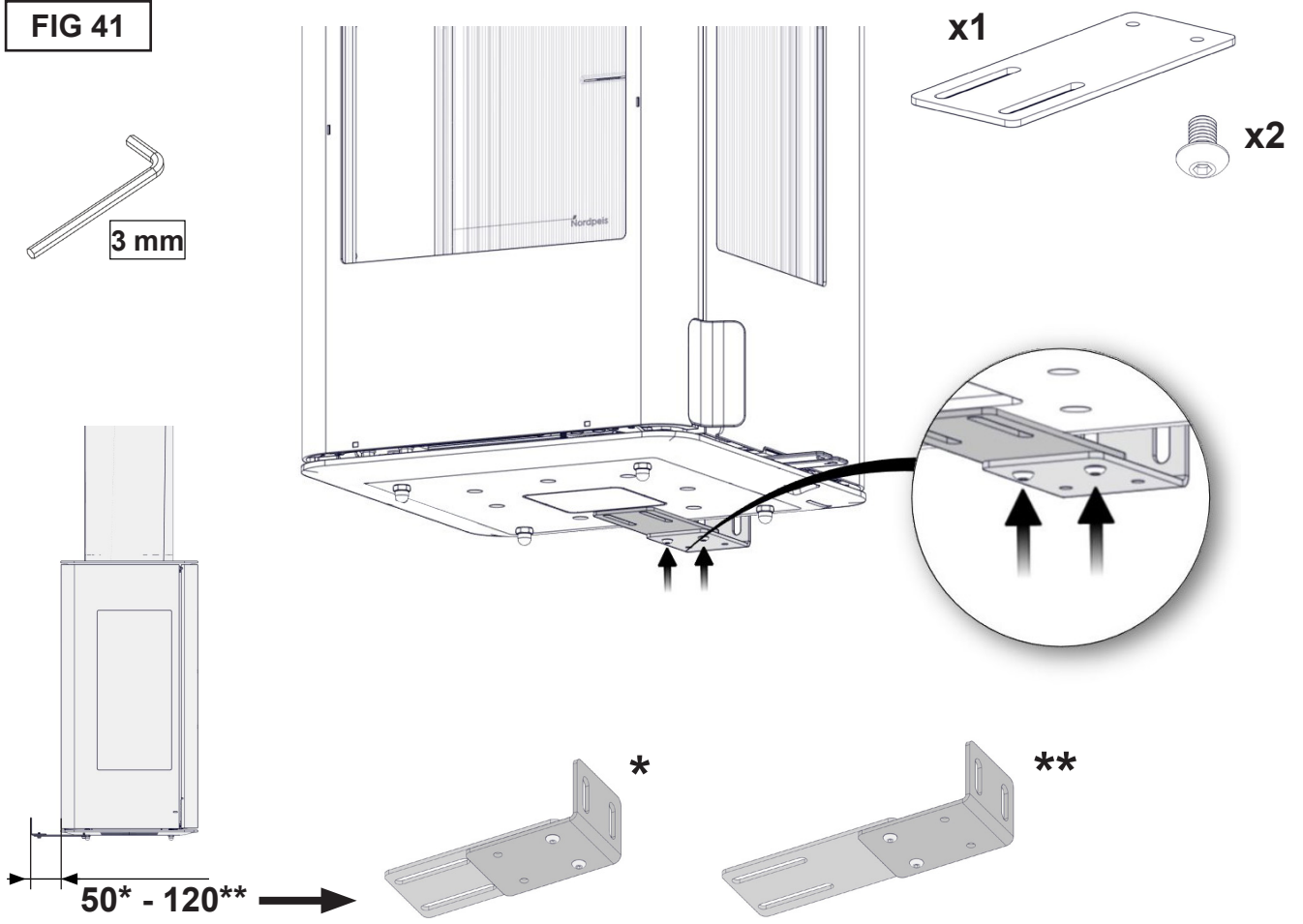

FIG 41 a

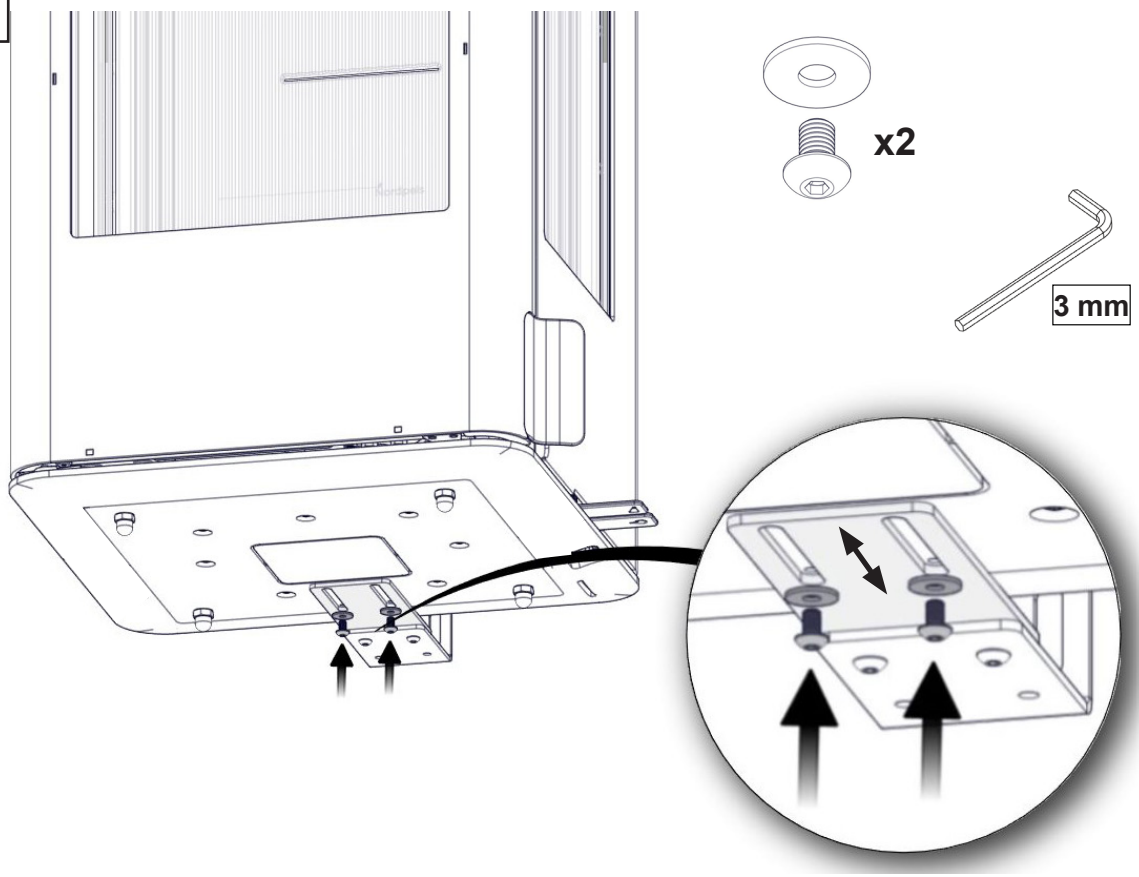
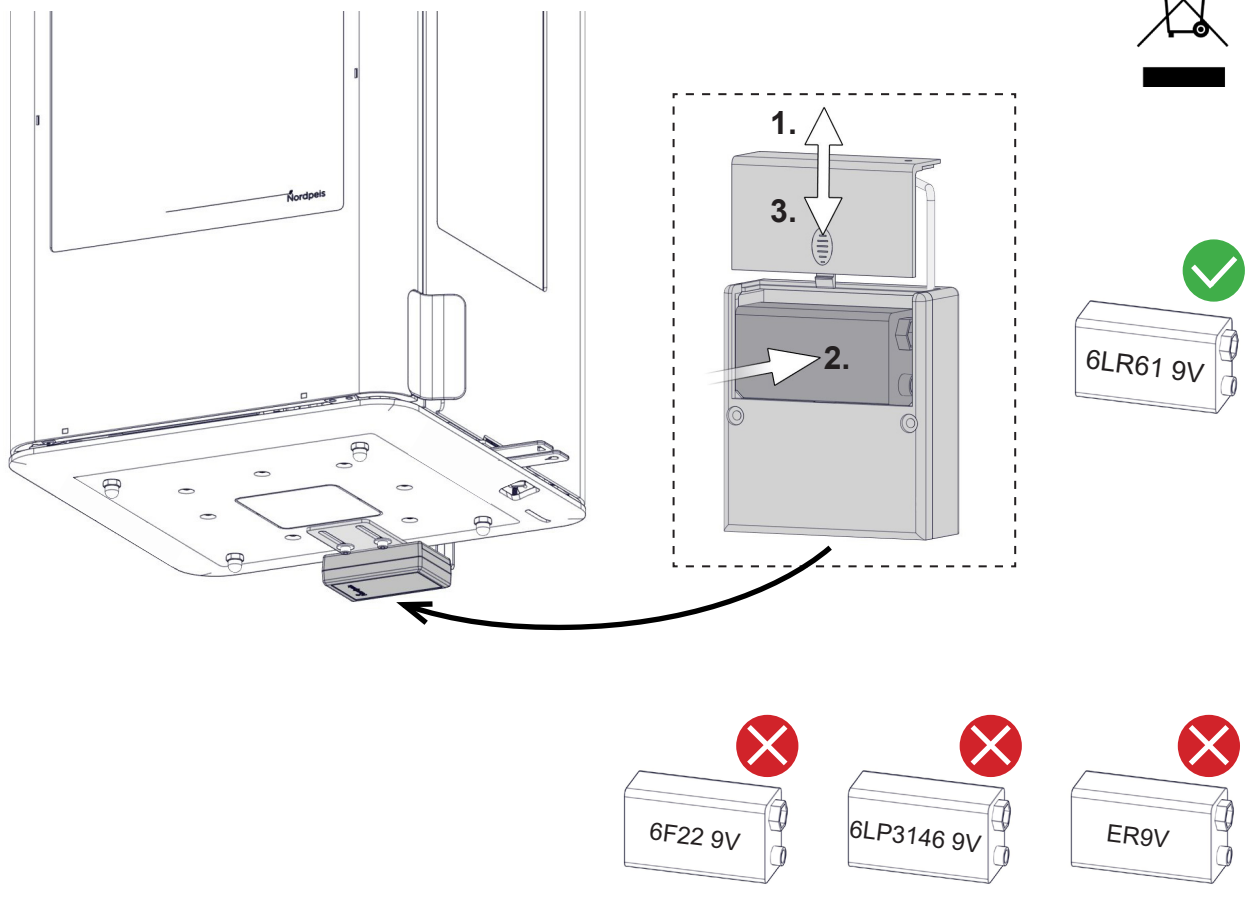

FIG 42



NO Batteriboksen må bare installeres på det stedet som er angitt i bruksanvisningen.

SE Batteriboxen får endast monteras på den plats som anges i monteringsanvisningen.

GB The battery box may only be installed in the location indicated in the manual.

FI Paristokotelon saa asentaa vain käyttöohjeessa ilmoitettuun paikkaan.

DE Der Batteriekasten darf nur an dem im Handbuch angegebenen Ort installiert werden.

FR Le boîtier de batterie ne peut être installé qu'à l'endroit indiqué dans le manuel.

FIG 43

**PLASSERING AV SERIENUMMER / POSITION OF THE SERIAL NUMBER
SARJANUMERON SIJAINTI / PLACERING AV SERIENUMMER
POSITION DER SERIENNUMMER / POSITION DU NUMÉRO DE SÉRIE**

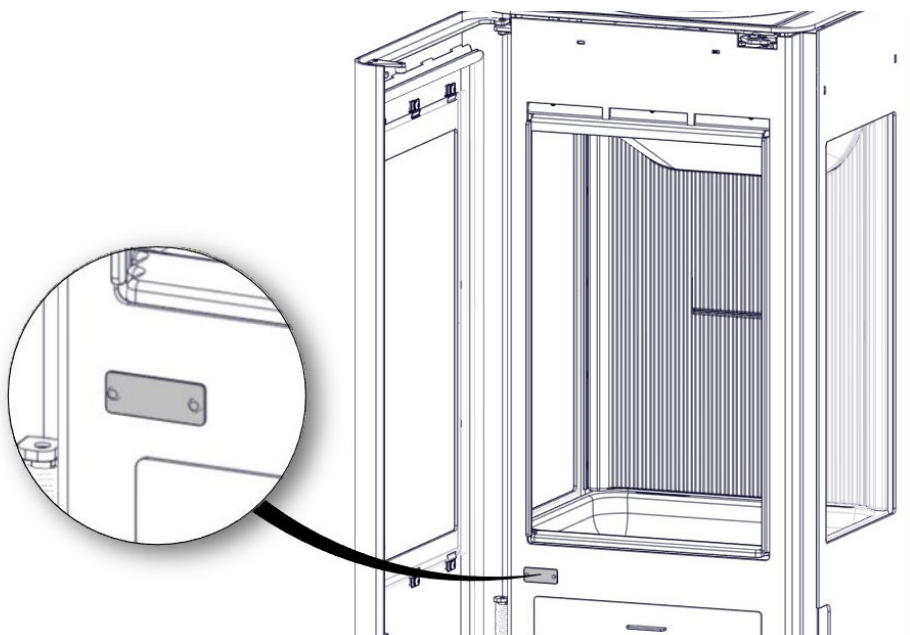

 Nordpeis

Nordpeis AS, Gjellebekkstubben 11, N-3420 LIERSKOGEN, Norway
www.nordpeis.com